



**COMMON PRE-BOARD EXAMINATION**  
**PHYSICS -Code No. 042**  
**Class-XII-(2025-26)**

**SET- 2**

**Time Allowed: 3 Hrs**

**Maximum Marks:70**

**GENERAL INSTRUCTIONS:**

Read the following instructions very carefully and follow them:

1. There are 33 questions in all. All questions are compulsory.
2. This question paper has five sections: Section A, Section B, Section C, Section D and Section E.
3. All the sections are compulsory.
4. Section A contains sixteen questions, twelve MCQ and four assertion reasoning based of 1 mark each, Section B contains five questions of two marks each, Section C contains seven questions of three marks each, Section D contains two case study-based questions of four marks each and Section E contains three long answer questions of five marks each.
5. There is no overall choice. However, an internal choice has been provided in two questions in Section B, one question in Section C and all three questions in Section E. You have to attempt only one of the choices in such questions.
6. Use of calculators is not allowed.
7. You may use the following values of physical constants wherever necessary.
  - i.  $c = 3 \times 10^8$  m/s
  - ii.  $m_e = 9.1 \times 10^{-31}$  kg
  - iii.  $m_p = 1.7 \times 10^{-27}$  kg
  - iv.  $e = 1.6 \times 10^{-19}$  C
  - v.  $\mu_0 = 4\pi \times 10^{-7}$  T m A<sup>-1</sup>
  - vi.  $h = 6.63 \times 10^{-34}$  J s
  - vii.  $\epsilon_0 = 8.854 \times 10^{-12}$  C<sup>2</sup>N<sup>-1</sup>m<sup>2</sup>
  - viii. Avogadro's number =  $6.023 \times 10^{23}$  per gram mole

**SECTION-A**

1. Out of the following options identify the one which can be used to produce a propagating electromagnetic wave 1  
(A) A chargeless particles (B) An accelerating charge  
(C) A charge moving at constant velocity (D) A stationary charge
2. In Young's double-slit experiment, the intensity of light at a point on the screen where the path difference is  $\lambda$  is  $k$  ( $\lambda$  being the wavelength of light used). The intensity at a point where the path difference is  $\lambda/4$ , will be 1  
(A)  $k$  (B)  $k/4$   
(C)  $k/2$  (D) zero
3. If the velocity of an electron increases, then its de-Broglie wavelength 1  
(A) increases (B) decreases  
(C) remains the same (D) first increases then decreases
4. The ratio of energies of the hydrogen atom in its first to second excited state is 1  
(A) 1 : 4 (B) 4 : 1  
(C) -4 : -9 (D) 9 : 4
5. A bird flies down vertically towards a water surface. To a fish inside the water, vertically below the bird, the bird will appear to 1  
(A) move faster than its actual speed (B) be at its actual distance  
(C) move slower than its actual speed (D) be closer than its actual distance
6. Increasing order of dielectric constant for air, rubber and copper is: 1  
(A)  $K_{\text{air}} < K_{\text{rubber}} < K_{\text{copper}}$  (B)  $K_{\text{air}} > K_{\text{rubber}} > K_{\text{copper}}$   
(C)  $K_{\text{air}} > K_{\text{rubber}} < K_{\text{copper}}$  (D)  $K_{\text{air}} < K_{\text{rubber}} > K_{\text{copper}}$

7. When an electron in an atom goes from a lower to a higher orbit, its kinetic energy (KE) and potential energy (PE) varies as  
 (A) KE increases, PE decreases (B) KE increases, PE increases  
 (C) KE decreases, PE increases (D) KE decreases, PE decreases
8. Assume that each diode shown in the figure has a forward bias resistance of  $50 \Omega$  and an infinite reverse bias resistance. The current through the  $150 \Omega$  resistance is

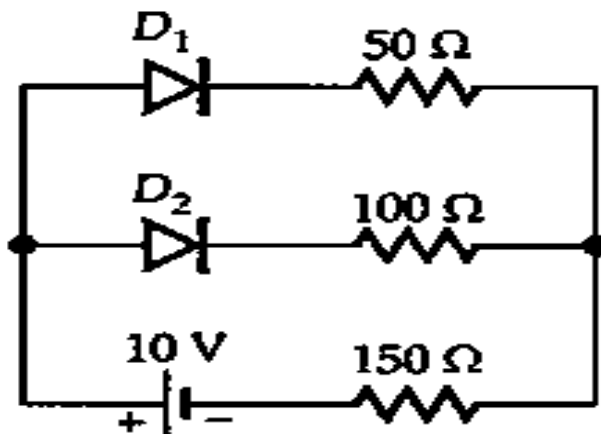

- (A) 0.04 A (B) zero  
 (C) 0.05 A (D) 0.66 A
9. If the speed of rotation of a dynamo is doubled, then the induced e.m.f. will  
 (A) become four times (B) become half  
 (C) become double (D) remain unchanged
10. Pure silicon at 300 K has equal electron ( $n_e$ ) and hole ( $n_h$ ) concentrations of  $1.5 \times 10^{16} \text{ m}^{-3}$ . Doping by indium increases  $n_h$  to  $4.5 \times 10^{22} \text{ m}^{-3}$ . The  $n_e$  in the doped silicon is  
 (A)  $3 \times 10^{19} \text{ m}^{-3}$  (B)  $9 \times 10^{-5} \text{ m}^{-3}$   
 (C)  $2.25 \times 10^{11} \text{ m}^{-3}$  (D)  $5 \times 10^9 \text{ m}^{-3}$
11. In the figure, if net force on Q is zero then the value of  $Q/q$  is:

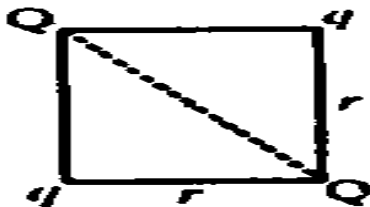

- (A)  $\sqrt{2}$  (B)  $2\sqrt{2}$   
 (C)  $1/2\sqrt{2}$  (D)  $1/\sqrt{2}$
12. A bar-magnet of the pole-strength  $2 \text{ Am}$  is kept in a magnetic field of induction  $4 \times 10^{-5} \text{ Wb/m}^2$  such that the axis of the magnet makes an angle  $30^\circ$  with the direction of the field. If the couple acting on the magnet is found to be  $80 \times 10^{-7} \text{ Nm}$ , then the distance between the poles of the magnet is:  
 (A) 20cm (B) 4cm  
 (C) 2cm (D) 8cm

**For Questions 13 to 16, two statements are given one labelled Assertion (A) and other labelled Reason (R). Select the correct answer to these questions from the options as given below.**

- (A) Both A and R are true and R is the correct explanation of A  
 (B) Both A and R are true and R is not the correct explanation of A  
 (C) A is true but R is false.  
 (D) Both A and R are false.
13. **Assertion (A):** In Young's experiment, the fringe width for dark fringes is different from that for white fringes.  
**Reason (R):** In Young's double slit experiment the fringes are performed with a source of white light, then only black and bright fringes are observed.
14. **Assertion (A):** When capacitive reactance is smaller than the inductive reactance in series L-C-R circuit, voltage leads the current.  
**Reason (R):** In series L-C-R circuit inductive reactance greater than capacitive reactance.

15. **Assertion (A):** If an electron and proton enter a magnetic field with equal momentum, then the paths of both of them will be equally curved. 1  
**Reason (R):** The magnitude of charge on an electron is same as that on a proton.
16. **Assertion (A):** The threshold frequency of the photoelectric effect supports the particle nature of light. 1  
**Reason (R):** If the frequency of incident light is less than the threshold frequency, electrons are not emitted from the metal surface.

**SECTION-B**

- 17(I) Draw 3 equipotential surfaces corresponding to a field that uniformly increases in magnitude but remains constant along Z-direction. How are these surfaces different from that of a constant electric field along Z-direction? 2

**OR**

- 17(II) Compare the individual dipole moment and the specimen dipole moment for H<sub>2</sub>O molecule and O<sub>2</sub> molecule when placed in the  
 (i) absence of external electric field and  
 (ii) presence of external electric field.  
 Justify your answer in each case.
18. Calculate the nearest distance of approach of an  $\alpha$ -particle of energy 2.5 eV being scattered by a gold nucleus ( $Z = 79$ ). 2
19. A ray of light incident normally on one face of a right isosceles prism is totally reflected as shown in figure. What must be minimum value of refractive index glass? Give relevant calculations. 2

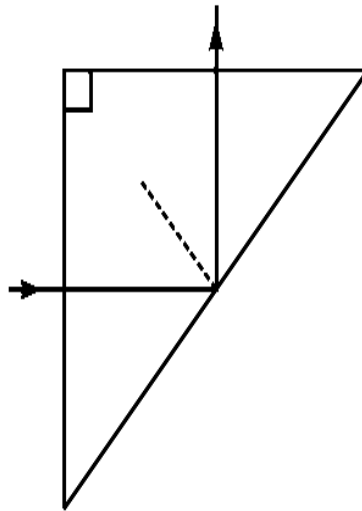

- 20(I) A length of wire carries a steady current. It is bent first to form a circular plane coil of one turn. The same length is now bent more sharply to give a double loop of smaller radius. When the same current is passed, find the ratio of the magnetic field at the centre with its first value. 2

**OR**

- 20(II) A galvanometer can be converted into a voltmeter of a certain range by connecting a resistance of 980  $\Omega$  in series with it. When the resistance is 470  $\Omega$  connected in series, the range is halved. Find the resistance of the galvanometer.
21. The susceptibility of a magnetic material is  $-2.6 \times 10^{-5}$ . 2  
 A) Identify the type of magnetic material and write an example for it  
 B) Show diagrammatically the behaviour of magnetic field lines in the presence of  
 (i) ferromagnetic and  
 (ii) diamagnetic substances.

**SECTION-C**

22. A) Give a brief description of the basic elementary process involved in the photoelectric emission in Einstein's picture. 3  
 B) When a photosensitive material is irradiated with light of frequency  $\nu$ , the maximum speed of electrons is given by  $V_{\max}$ . A plot of  $V_{\max}^2$  is found to vary with frequency  $\nu$  as shown in the figure.

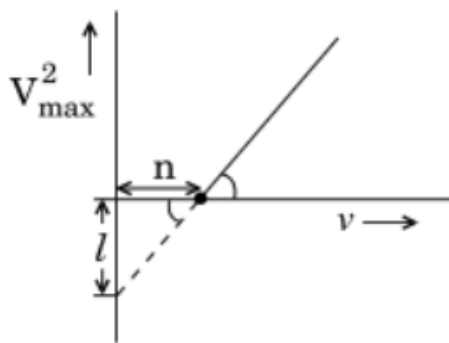

Use Einstein's photoelectric equation to find the expressions for

- (i) Planck's constant and
- (ii) work function of the given photosensitive material, in terms of the parameters  $l$ ,  $n$  and mass  $m$  of the electron.

23(I) A capacitor of unknown capacitance, a resistor of  $100 \Omega$  and an inductor of self-inductance  $L = (4/\pi^2)$  henry are connected in series to an ac source of 200 V and 50 Hz. 3

- A) Calculate the value of the capacitance and impedance of the circuit when the current is in phase with the voltage.
- B) Calculate the power dissipated in the circuit.

**OR**

23(II) A) Show diagrammatically two different arrangements used for winding the primary and secondary coils in a transformer. 3

- B) The numbers of turns in the primary and secondary coils of a transformer are 2000 and 50 respectively. The primary coil is connected to main of 120 V and secondary to a night bulb of 0.6 ohm. The efficiency of transformer is 80 %. Find voltage across the secondary of transformer and current in primary coil.

24. A) Draw a graph showing the variation of magnetic field with distance  $r$  from straight infinite current carrying wire. 3

- B) Two identical loops P and Q each of radius 5 cm are lying in perpendicular planes such that they have a common centre as shown in the figure. Find the magnitude and direction of the net magnetic field at the common centre of the two coils, if they carry currents equal to 3A and 4A respectively.

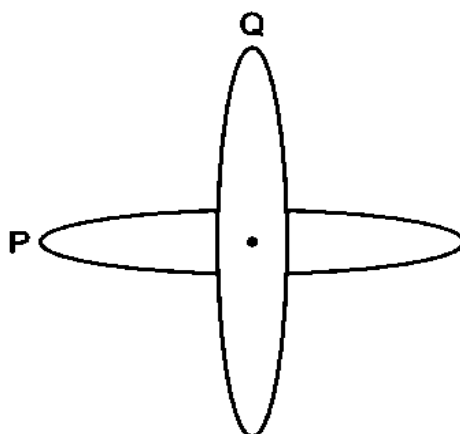

25. The current flowing through an inductor of self-inductance  $L$  is continuously increasing. Plot a graph showing the variation of: 3

- A) Magnetic flux versus the current
- B) Induced emf versus  $di/dt$ .
- C) Magnetic potential energy stored versus the current.

26. Electromagnetic waves with wavelength 3

- (i)  $\lambda_1$  is used in satellite communication.
- (ii)  $\lambda_2$  is used to kill germs in water purifier.
- (iii)  $\lambda_3$  is used to detect leakage of oil in underground pipelines.

- A) Identify and name the part of electromagnetic spectrum to which these radiations belong.  
 B) Write one more application of each.
27. A) Two nuclei have mass number in the ratio 1 : 2. Find the ratio of their nuclear densities. 3  
 B) Suppose we think of fission of a  ${}_{26}\text{Fe}^{56}$  nucleus into two equal fragments,  ${}_{13}\text{Al}^{28}$ . Is the fission energetically possible? Argue by working out  $Q$  of the process. Given,  $m({}_{26}\text{Fe}^{56}) = 55.93494 \text{ u}$  and  $m({}_{13}\text{Al}^{28}) = 27.98191 \text{ u}$
28. A capacitor  $C$ , a variable resistor  $R$  and a bulb  $B$  are connected in series to the AC mains in the circuit as shown in the figure. The bulb glows with some brightness. How will the glow of the bulb change if (i) a dielectric slab is introduced between the plates of the capacitor keeping resistance  $R$  to be the same (ii) the resistance  $R$  is increased keeping the same capacitance. Give reason for your answer in each case. 3

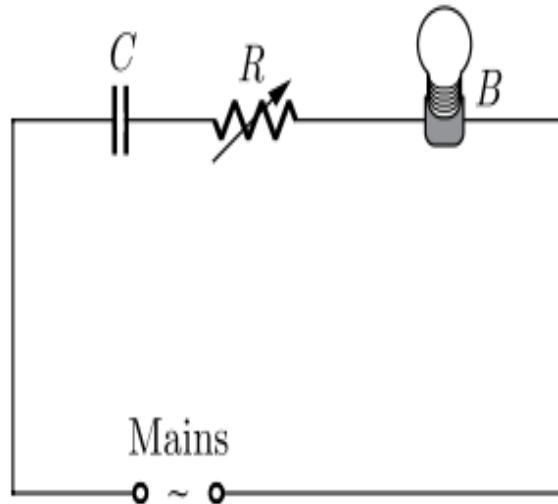

#### SECTION-D

29. The main difference between interference and diffraction is that interference results from the superposition of waves from two or more coherent sources, while diffraction is the bending of a single wave as it passes through an aperture or around an obstacle. This leads to other key differences: interference patterns have uniform fringe widths and completely dark/bright fringes, whereas diffraction patterns have non-uniform fringe widths and the dark fringes are never completely dark.
- (I) How is the spacing between fringes in a double slit experiment affected if: 2  
 (i) the slits separation is increased,  
 (ii) the colour of light used is changed from red to blue  
 Justify your answer in each case.
- (II) What type of wavefront will emerge from a 1  
 (i) point source and (ii) distant light source?
- (III) How does the angular separation between fringes in single-slit diffraction experiment change 1  
 when the distance of separation between the slit and screen is doubled?
- 30 A charge is a property associated with the matter due to which it experiences and produces an electric and magnetic field. Charges are scalar in nature and they add up like real numbers. Also, the total charge of an isolated system is always conserved. When the objects rub against each other charges acquired by them must be equal and opposite.

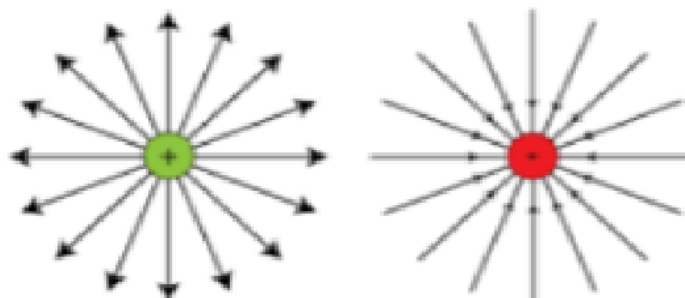

- (I) The cause of charging is: 1  
 (A) the actual transfer of protons (B) the actual transfer of neutrons  
 (C) the actual transfer of electrons (D) the actual transfer of any particle
- (II) Pick the correct statement. 1  
 i. The glass rod gives protons to silk when they are rubbed against each other.  
 ii. The glass rod gives electrons to silk when they are rubbed against each other.  
 iii. The glass rod gains protons from silk when they are rubbed against each other.  
 iv. The glass rod gains electrons when they are rubbed against each other.  
 (A) Option (i) (B) Option (ii)  
 (C) Option (iii) (D) Option (iv)
- (III) If two electrons are each  $1.5 \times 10^{-10}$  m from a proton, as shown in figure, magnitude of the net electric force they will exert on the proton is ( $\cos 65^\circ = 0.56$ ). 1

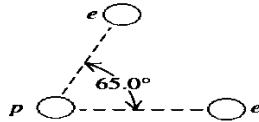

- (A)  $1.97 \times 10^{-8}$  N (B)  $3.83 \times 10^{-8}$  N  
 (C)  $4.63 \times 10^{-8}$  N (D)  $2.73 \times 10^{-8}$  N
- (IV) A charge is a property associated with the matter due to which it produces and experiences: 1  
 (A) electric effects only (B) magnetic effects only  
 (C) both electric and magnetic effects (D) no electric and magnetic effects

### SECTION-E

- 31(I) A) Establish a relation between electric current and drift velocity. 2+  
 B) A potential difference  $V$  is applied across the ends of copper wire of length  $l$  and diameter  $D$ . What is the effect on drift velocity of electrons if 3  
 (i)  $V$  is halved  
 (ii)  $l$  is doubled  
 (iii)  $D$  is halved

**OR**

- 31(II) A) Define the term 'Mobility' of charge carries in a conductor. Write its SI unit. What is its relation with relaxation time? 3+  
 B) Determine the current in each branch of the network shown in figure. 2

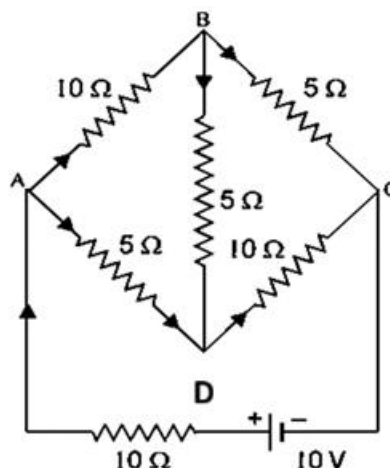

- 32(I) A) Draw a labelled ray diagram to show the image formation in an astronomical telescope. Obtain an expression for 3+  
 (i) the angular magnifying power 2  
 (ii) length of the tube of an astronomical telescope in its 'normal adjustment' position.  
 B) You are given two converging lenses of focal length 1.25 cm and 5 cm to design a compound microscope. If it is desired to have a magnification of 30, then find out the separation between the objective and eyepiece.

**OR**

- 32(II) A) Obtain a relation between focal length, radius of curvature and refractive index of a convex surface, using proper diagram. 2+  
 1+  
 B) A convex lens made up of glass of refractive index 1.5 is dipped in a medium of refractive index 1.25. Whether it will behave as a converging or a diverging lens? 2  
 C) A converging and a diverging lens of equal focal lengths are placed coaxially in contact. Find the power and the focal length of the combination.
- 33(I) Device X' shown here, converts the input voltage waveform into the output voltage waveform as shown in fig. 1+  
 3+  
 1

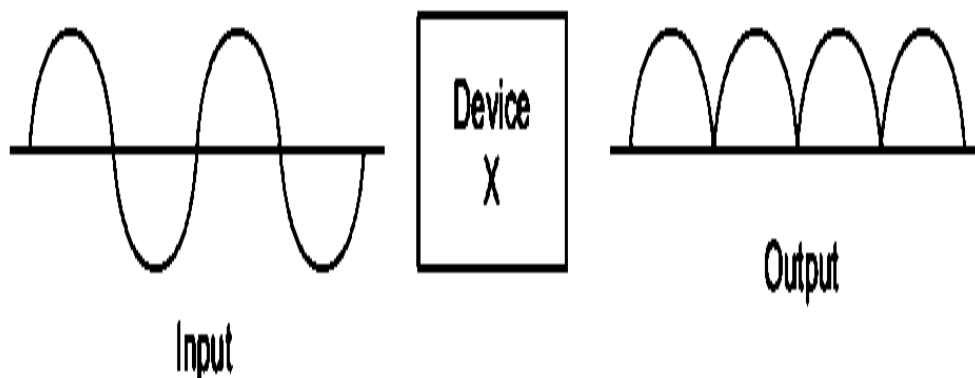

- A) Name the device X.  
 B) With a neat labelled diagram explain the construction of the device X.  
 C) An ac input signal of frequency 60 Hz is given to the device X. Write the frequency of the output signal.

**OR**

- 33(II) A) Name the important process that occurs during the formation of a p-n junction. 1+  
 B) Explain briefly, with the help of a suitable diagram, how a p-n junction is formed. 2+  
 C) Define the term 'barrier potential'. 1+  
 D) Draw V – I characteristics of a p–n junction diode. 1