



COMMON PRE-BOARD EXAMINATION

SCIENCE –Code No. 086

CLASS-X-(2025-26)

SET: 1



Time allowed: 3 Hrs.

Maximum Marks: 80

General Instructions

Read the following instructions very carefully and follow them:

(i) This question paper consists of 39 questions in 3 sections. Section A is Biology, Section B is Chemistry and Section C is Physics.

(ii) All questions are compulsory. However, an internal choice is provided in some questions. A student is expected to attempt only one of these questions.

Q. No.	SECTION - A	Marks
1	Which of the following organisms do not have a digestive system? A. Amoeba B. Earthworm C. Hydra D. Human	1
2	If a plant is kept in the dark for 48 hours, which process will continue to occur? A. Photosynthesis B. Transpiration C. Respiration D. None of these	1
3	A person's mouth waters on seeing his favorite food. This is an example of A. reflex action B. conditioned reflex C. voluntary action D. involuntary action	1
4	A student becomes very nervous before an exam; his heartbeat increases and palms become sweaty. Which hormone is responsible? A. Adrenaline B. Insulin	1

	C. Thyroxine D. Estrogen	
5	A man with blood group 'A' marries a woman with blood group 'B'. Their child has blood group 'O'. Which of the following is true? A. Both parents are homozygous B. Both parents carry recessive 'i' allele C. Only father carries recessive 'i' D. Both parents are Rh positive	1
6	A fish population in a lake starts declining after detergent waste enters the water. The main cause is A. Increase in oxygen level B. Decrease in oxygen level C. Temperature fall D. Growth of aquatic plants only	1
7	In a food chain, DDT concentration is highest in — (i) Phytoplankton (ii) Zooplankton (iii) Small fish (iv) Large fish (v) Fish-eating birds A. (i), (ii), (iii) B. (ii), (iii), (iv) C. (iii), (iv), (v) D. (i), (iv), (v)	1
<p>The following two questions consist of two statements – Assertion (A) and Reason (R). Answer these questions by selecting the appropriate option given below:</p> <p>A. Both A and R are true, and R is the correct explanation of A. B. Both A and R are true, and R is not the correct explanation of A. C. A is true but R is false. D. A is false but R is true.</p>		
8	Assertion (A): Heterozygous tall pea plant (Tt) self-pollinates, producing some short offspring. Reason (R): The short trait reappears due to independent assortment of alleles.	1

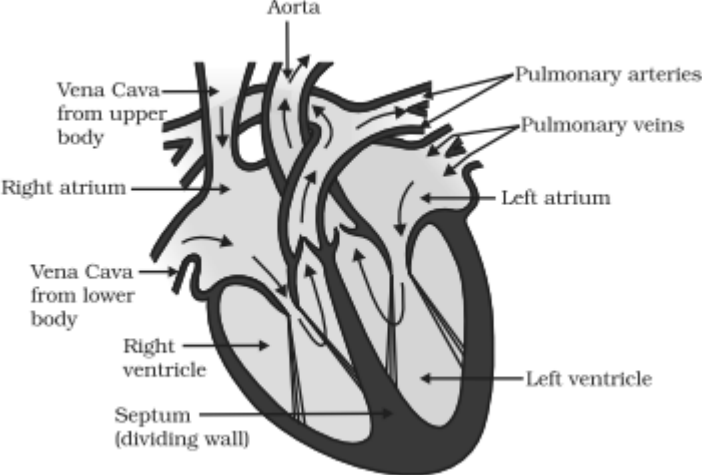
9	<p>Assertion (A): Wearing sunscreen can help reduce harmful effects of UV-B radiation on skin.</p> <p>Reason (R): Sunscreens contain chemicals that absorb or block UV radiation from reaching the skin.</p>	1
10	How does the nephron prevent loss of useful substances like glucose and amino acids?	2
11	<p>Observe the given sectional view of the human heart and the questions that follow.</p>  <p><i>Students to attempt either option A or B.</i></p> <p>A. What is the role of valves in the heart? What would happen if they did not function correctly?</p> <p style="text-align: center;">OR</p> <p>B. What is the function of the muscular wall called the septum that divides the heart?</p>	2
12	<p>A pond ecosystem has the following food chain:</p> <p>Algae → small fish → big fish → kingfisher. Assign trophic levels to each.</p>	2
13	How does the human brain control and coordinate voluntary and involuntary actions?	3
14	<p>A dihybrid cross was made between two pea plants — one with round yellow seeds (RrYy) and another also round yellow seeds (RrYy).</p> <p>(i) What types of gametes will be formed?</p> <p>(ii) Give the phenotypic ratio in F₂ generation.</p> <p>(iii) Name the Mendel's law shown by this experiment.</p>	3
15	<p>Rahul was running a 400 m race during his school sports day. After completing the race, he started breathing heavily. His teacher explained that this happens because his muscles required extra energy during the activity.</p> <p><u>Attempt either subpart A or B.</u></p> <p>A. How do the circulatory system and the respiratory system work together to meet the increased energy demand of Rahul's muscles during running?</p> <p style="text-align: center;">OR</p>	4

	<p>B. When Rahul's muscles did not get enough oxygen during running, which type of respiration might have occurred in his muscle cells? Write the equation for this process.</p> <p>C. Which compound is broken down in the cells to release energy?</p> <p>D. Why does aerobic respiration produce more ATP compared to anaerobic respiration?</p> <p><u>For visually impaired students</u></p> <p>D. Why did Rahul start breathing faster after running?</p>	
16	<p><u>Attempt either option A or B.</u></p> <p>A. Riya wanted to grow potato plants in her garden.</p> <p>(i) Suggest a suitable method for growing potato plants and explain why this method is preferred over growing from seeds.</p> <p>(ii) Sometimes small differences are seen among the potato plants even when propagated vegetatively. What causes these differences, and are they beneficial or harmful?</p> <p style="text-align: center;">OR</p> <p>B. Anita is studying human reproduction for her biology project. She observes that a female releases an egg every month and learns that pregnancy occurs only if this egg is fertilized by a sperm. She also studies the journey of the fertilized egg into the uterus.</p> <p>(i) Explain how fertilization occurs in humans. Where does it take place?</p> <p>(ii) Describe what happens after fertilization until the embryo is implanted in the uterus.</p>	5
SECTION - B		
17	<p>Analyze the following chemical equations and identify the correct values for 'p' and 'q'.</p> <p>Equation 1: $p\text{Mg (s)} + \text{O}_2\text{(g)} \longrightarrow 2\text{MgO(s)}$</p> <p>Equation 2: $2\text{Pb(NO}_3)_2\text{(s)} \longrightarrow q\text{PbO (s)} + 4\text{NO}_2\text{(g)} + \text{O}_2\text{(g)}$</p> <p>A. $p = 1, q = 1$</p> <p>B. $p = 2, q = 4$</p> <p>C. $p = 1, q = 2$</p> <p>D. $p = 2, q = 2$</p>	1
18	<p>When 2 mL of sodium hydroxide solution is added to few pieces of granulated zinc in a test tube and then warmed, the reaction that occurs can be written in the form of a balanced chemical equation as:</p> <p>A. $\text{NaOH} + \text{Zn} \longrightarrow \text{NaZnO}_2 + \text{H}_2\text{O}$</p> <p>B. $2\text{NaOH} + \text{Zn} \longrightarrow \text{Na}_2\text{ZnO}_2 + \text{H}_2$</p> <p>C. $2\text{NaOH} + \text{Zn} \longrightarrow \text{NaZnO}_2 + \text{H}_2$</p> <p>D. $2\text{NaOH} + \text{Zn} \longrightarrow \text{Na}_2\text{ZnO}_2 + \text{H}_2\text{O}$</p>	1
19	<p>A farmer finds her soil to be too acidic (low pH). She decides to treat the soil with slaked</p>	1

	lime. What will be the effect of this action on the soil's pH? A. The pH will decrease further. B. The pH will remain unchanged. C. The pH will increase. D. The soil will become water-logged.																
20	<p>What change would you observe if you put blue litmus paper and red litmus paper into a sample of soap solution?</p> <table border="1"> <thead> <tr> <th></th> <th>Colour change on Blue Litmus</th> <th>Colour change on Red Litmus</th> </tr> </thead> <tbody> <tr> <td>A</td> <td>No change</td> <td>Turns blue</td> </tr> <tr> <td>B</td> <td>Turns red</td> <td>No change</td> </tr> <tr> <td>C</td> <td>Turns red</td> <td>Turns blue</td> </tr> <tr> <td>D</td> <td>No change</td> <td>No change</td> </tr> </tbody> </table>		Colour change on Blue Litmus	Colour change on Red Litmus	A	No change	Turns blue	B	Turns red	No change	C	Turns red	Turns blue	D	No change	No change	1
	Colour change on Blue Litmus	Colour change on Red Litmus															
A	No change	Turns blue															
B	Turns red	No change															
C	Turns red	Turns blue															
D	No change	No change															
21	<p>Consider the reaction: $\text{CaO}_{(s)} + \text{H}_2\text{O}_{(l)} \longrightarrow \text{Ca(OH)}_2 \text{ aq} + \text{Heat}$</p> <p>This reaction can be classified as:</p> <p>(i) Combination reaction (ii) Exothermic reaction (iii) Decomposition reaction (iv) Endothermic reaction</p> <p>A. (iii) and (iv) B. (i) and (ii) C. (i) and (iv) D. (ii) and (iii)</p>	1															
22	<p>A strip of zinc is added to a test tube containing aqueous ferrous sulphate, and a copper wire is added to another test tube containing aqueous zinc sulphate. Which of the following observations is correct?</p> <p>A. The green solution in the first test tube turns colourless, and the second test tube remains colourless with no change. B. There is no reaction in the first test tube, but the blue solution in the second test tube turns colourless. C. A brown coating is observed on the zinc strip, and a grey coating is observed on the copper wire. D. The solution in both test tubes turns black, and a gas is evolved.</p>	1															
23	<p>A student takes 10 mL of a hydrochloric acid solution (pH = 2) in a beaker and adds 90 mL of distilled water to it. What will be the effect on the pH of the final solution?</p>	1															

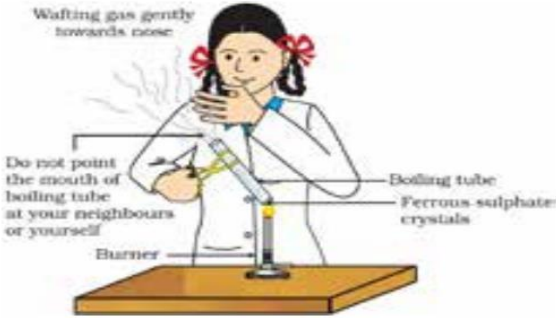
	<p>A. The pH will decrease.</p> <p>B. The pH will increase.</p> <p>C. The pH will remain unchanged.</p> <p>D. The pH will become 1.</p>	
<p>The following question consist of two statements – Assertion (A) and Reason (R). Answer this question by selecting the appropriate option given below:</p> <p>A. Both A and R are true, and R is the correct explanation of A.</p> <p>B. Both A and R are true, and R is not the correct explanation of A.</p> <p>C. A is true but R is false.</p> <p>D. A is false but R is true.</p>		
24	<p>Assertion (A): C_4H_8, C_4H_6 and C_4H_{10} are members of the same homologous series</p> <p>Reason (R): C_4H_8, C_4H_6, C_3H_4, C_3H_6, C_2H_4, C_2H_2 are unsaturated hydrocarbons.</p>	1
25	<p>(a) When a piece of calcium metal is dropped into a beaker of water, it starts floating on the surface after some time. Provide a scientific reason for this observation.</p> <p>(b) Noble metals like gold, silver, and platinum do not react even with steam. What conclusion can be drawn about their position in the reactivity series?</p>	2
26	<p>In a laboratory activity, a student takes a small amount of green-coloured ferrous sulphate heptahydrate ($FeSO_4 \cdot 7H_2O$) crystals in a dry boiling tube and heats it over a flame.</p>  <p>(a) What is the first observable change in the colour of the crystals? What does this change indicate?</p> <p>(b) Upon stronger heating, which two gases are evolved? Describe the characteristic smell of one of these gases.</p> <p>(c) What is the colour and chemical name of the solid compound left behind in the boiling tube after strong heating?</p>	3
27	<p><u>Attempt either option A or B.</u></p> <p>A.</p> <p>Metal oxides are formed when metals react with oxygen. Their chemical nature can vary.</p> <p>(i) Give an example of a metal oxide that is basic.</p>	3

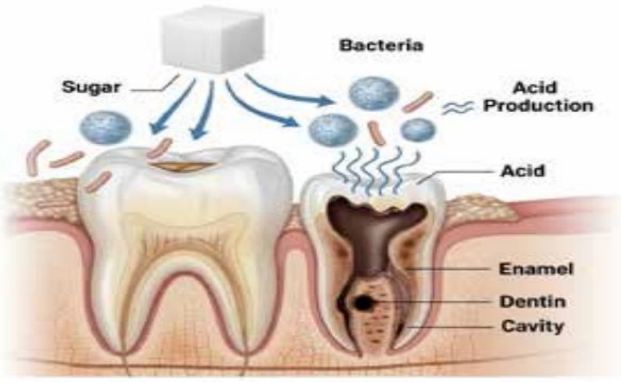
	<p>(ii) Give an example of a metal oxide that shows amphoteric behaviour.</p> <p>(iii) Write a balanced chemical equation to show the reaction of an amphoteric oxide (e.g., zinc oxide) with a strong acid (e.g., HCl).</p> <p style="text-align: center;">OR</p> <p>B.</p> <p>The way metals react with water depends on their chemical reactivity.</p> <p>(i) Name one metal that reacts violently with cold water, producing a flame.</p> <p>(ii) Name a metal that does not react with cold or hot water but reacts only with steam.</p> <p>(iii) Write the balanced chemical equation for the reaction of iron with steam.</p>	
28	<p>Tooth enamel, the hardest substance in the human body, is made of calcium phosphate. It does not dissolve in water but is corroded when the pH in the mouth is below 5.5. Bacteria present in the mouth produce acids by the degradation of sugar and food particles.</p>  <p>A. What is the chemical nature of the substance responsible for tooth decay?</p> <p>B. Explain why tooth enamel, which is a salt, begins to corrode in an acidic medium.</p> <p style="text-align: center;">OR</p> <p>How does the regular use of a good quality toothpaste help in preventing this decay?</p> <p>C. What is a neutralization reaction? Give one example from daily life where it is used.</p>	4
29	<p><u>Attempt either option A or B.</u></p> <p>A.</p> <p>The molecular formula of a saturated hydrocarbon is C_4H_{10}.</p> <p>(a) Draw the structural formula of its straight-chain isomer and provide its IUPAC name.</p> <p>(b) Draw the structural formula of its branched-chain isomer and provide its IUPAC name.</p>	5

	<p>(c) What is the relationship between these two compounds called? Define this phenomenon.</p> <p>(d) Explain why the boiling point of the straight-chain isomer is higher than that of the branched-chain isomer.</p> <p>(e) Write the balanced chemical equation for the complete combustion of this hydrocarbon.</p> <p style="text-align: center;">OR</p> <p>B.</p> <p>Carbon is an element that forms the basis for all life. It belongs to Group 14 of the periodic table and exhibits unique properties.</p> <p>(a) What is the valency of Carbon? Name the property of carbon which allows it to form long chains with itself.</p> <p>(b) Carbon exists in various forms with different physical properties but identical chemical properties. What are these different forms called? Name one hard and one soft crystalline form.</p> <p>(c) Draw the structure of the hard crystalline form you named in part (b).</p> <p>(d) What type of bonds are present in compounds of carbon? Give a reason why these compounds are generally poor conductors of electricity.</p> <p>(e) Write the name and draw the electron dot structure of the simplest compound formed between carbon and hydrogen.</p>	
SECTION - C		
30	<p>Arjun observed the reflection of light from different types of spherical mirrors and made the following statements:</p> <p>I. A concave mirror can form a magnified and real image of an object.</p> <p>II. A convex mirror can only form a virtual image of an object.</p> <p>III. The magnification produced by a concave mirror can be negative.</p> <p>Choose from the following the correct option that lists the correct statements.</p> <p>A. I and II.</p> <p>B. I and III.</p> <p>C. I, II and III.</p> <p>D. II and III.</p>	1
31	<p>When a beam of white light passes through a glass prism, the light separates into its constituent colors. Choose the correct option that explains this phenomenon.</p> <p>A. The different colors of light travel at the same speed inside the prism.</p>	1

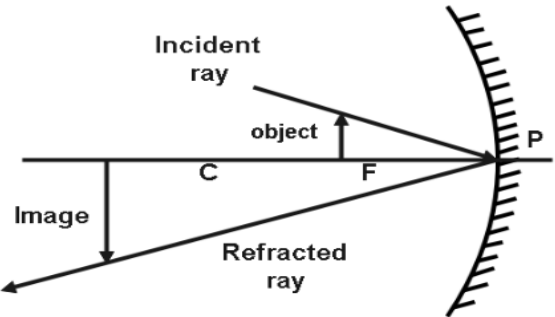
	<p>B. The different colors of light are refracted at different angles due to their different speeds inside the prism.</p> <p>C. The prism itself produces the colors and this effect is due to the scattering of light by the prism material.</p> <p>D. The angle of incidence is different for each color of light, leading to the separation of colors.</p>	
<p>The following question consist of two statements – Assertion (A) and Reason (R). Answer this question by selecting the appropriate option given below:</p> <p>A. Both A and R are true, and R is the correct explanation of A.</p> <p>B. Both A and R are true, and R is not the correct explanation of A.</p> <p>C. A is true but R is false.</p> <p>D. A is false but R is true.</p>		
32	<p>Assertion (A): A convex lens of focal length 20 cm is placed in front of an object at 10 cm. The image formed will be virtual and erect.</p> <p>Reason (R): For a convex lens, when the object is placed between the optical center and the principal focus, it forms a virtual and erect image</p>	1
33	<p>The diagram shows a concave mirror reflecting rays of light.</p>  <p>A. Explain what is meant by the principal focus of a concave mirror.</p> <p>B. State the mathematical relationship between the radius of curvature and focal length of a spherical mirror.</p> <p>C. Draw a ray diagram for image formation when the object is placed at infinity.</p>	2
34	<p><u>Attempt either option A or B.</u></p> <p>A. In the given circuit, find:</p> <p>(i) Total resistance of the network of resistors.</p> <p>(ii) Current through ammeter A.</p>	2

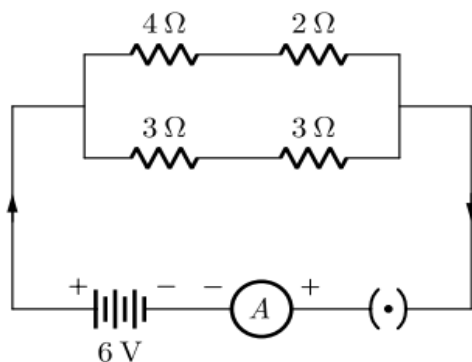

OR

B. Study the given electric circuit and calculate:

- (i) The current flowing through the $4\ \Omega$ resistor.
- (ii) Potential difference across the combination of two resistor of $8\ \Omega$ each.

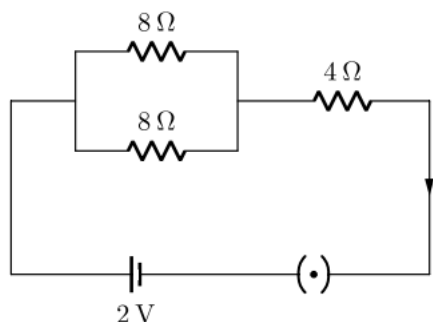

35	<p>A person wears spectacles of power -2.5 D.</p> <ol style="list-style-type: none"> (i) Name the defect of vision he is suffering from. <p>Draw the ray diagram for:</p> <ol style="list-style-type: none"> (ii) The defective eye. (iii) Its correction after using a suitable lens. 	3
36	<p>Two resistors of resistances $3\ \Omega$ and $6\ \Omega$ respectively are connected to a battery of 6 V so as to have maximum resistance and maximum current.</p> <ol style="list-style-type: none"> (i) How will you connect the resistances in each case? (ii) Calculate the strength of the current in the circuit in both cases. 	3
37	<p>Answer the following questions:</p> <ol style="list-style-type: none"> (i) What is the direction of magnetic field lines outside a bar-magnet? (ii) The magnetic field lines in a given region are getting crowded. What does it indicate? (iii) State one advantage of AC over DC. 	3

38	<p>Convex mirror is used as a rear-view mirror in vehicles. Since the image of the object formed is small in size, the field of view is increased. Convex mirror is also used in street lights to diverge light over a large area.</p>  <p>A. In driver's mirror, what type of image is formed behind the vehicle? B. What can you say about field of view of a convex mirror? <u>Attempt either subpart C or D.</u> C. Draw the ray diagram for the convex mirror used as rear view mirror in vehicle. D. An object is kept at a distance of 15 cm in front of a convex mirror of focal length 10cm. Find the position of the object.</p>	4
39	<p><u>Attempt either option A or B</u></p> <p>A.</p> <p>(i) State Joules law of heating. List two special characteristics of a heating element wire. (ii) An electric iron consumes energy at the rate of 880W when heating is at the maximum rate and 440W when the heating is at the minimum rate. The applied voltage is 220 V. Calculate the current and resistance in each case.</p> <p style="text-align: center;">OR</p> <p>B.</p> <p>(i) Define electric power. Write its SI unit. Derive the expression for electric power in terms of potential difference (V) and resistance (R). An electric bulb is rated 220 V, 100 W. Calculate:</p> <p>(ii) The current drawn by the bulb. (iii) The resistance of the bulb. (iv) The energy consumed by the bulb in 5 hours.</p>	5