



COMMON PRE-BOARD EXAMINATION

PHYSICS-Code No. 042

Class-XII-(2025-26)

SET: 3



Time allowed: 3 Hrs.

Maximum Marks: 70

General Instructions:

Read the following instructions very carefully and follow them:

- There are 33 questions in all. All questions are compulsory.
- This question paper has five sections: Section A, Section B, Section C, Section D and Section E.
- All the sections are compulsory.
- Section A contains sixteen questions, twelve MCQ and four assertion reasoning based of 1 mark each, Section B contains five questions of two marks each, Section C contains seven questions of three marks each, Section D contains two case study-based questions of four marks each and Section E contains three long answer questions of five marks each.
- There is no overall choice. However, an internal choice has been provided in two questions in Section B, one question in Section C and all three questions in Section E. You have to attempt only one of the choices in such questions.
- Use of calculators is not allowed.
- You may use the following values of physical constants where ever necessary

i) $c = 3 \times 10^8$ m/s

ii) $m_e = 9.1 \times 10^{-31}$ kg

iii) $m_p = 1.7 \times 10^{-27}$ kg

iv) $e = 1.6 \times 10^{-19}$ C

v) $\mu_0 = 4\pi \times 10^{-7}$ T m A⁻¹

vi) $h = 6.63 \times 10^{-34}$ J s

vii) $\epsilon_0 = 8.854 \times 10^{-12}$ C²N⁻¹m⁻²

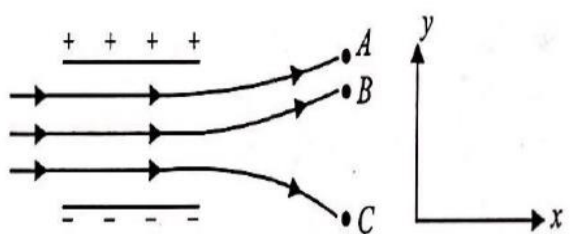

viii) Avogadro's number = 6.023×10^{23} per gram mole

SECTION A

| | | | |
|-------|---|--|---|
| 1. | The given figure shows tracks of three charged particles in a uniform electrostatic field. Which particle has the highest charge to mass ratio? |  | 1 |
| (A) A | (B) B | | |
| (C) C | (D) All are equal | | |

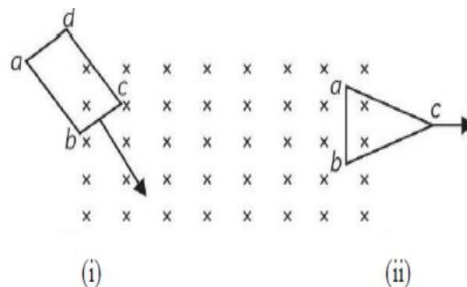
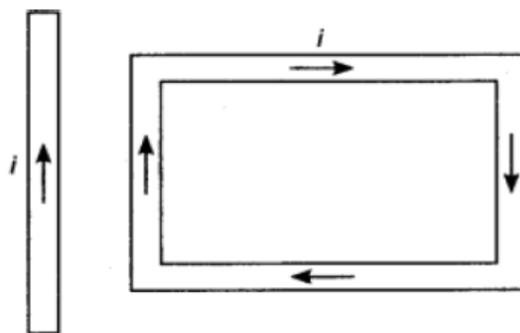
| | | |
|----|---|---|
| 2. | Drift velocity of the free electrons in a conducting wire carrying a current 'i' is v. If in a wire of the same metal, but of double the radius, the current be '2i' then the drift velocity of the electrons will be (A) v/4 (B) v/2 (C) v (D) 4v | 1 |
| 3. | An electron in an atom revolves around the nucleus in an orbit of radius r with frequency f, the magnetic moment of electron is (A) $ef\pi r^2$ (B) $ef\pi r^2/2$ (C) $2ef\pi r^2$ (D) $ef\pi r^2/3$ | 1 |
| 4. | A rectangular loop carrying a current 'i' is situated near a long straight wire such that the wire is parallel to the one of the sides of the loop and is in the plane of the loop. If a steady current I is established in wire as shown in figure, the loop will (A) Rotate about an axis parallel to the wire. (B) Move away from the wire or towards right. (C) Move towards the wire or towards Left. (D) Remain stationary. | 1 |
| 5. | Below figure shows planar loops of different shapes moving out or into a region of magnetic field which is directed normal to the plane of the loop away from the reader. The direction of induced current in each loop using Lenz's law will be: (A) (i) badcb; (ii) bcab (B) (i) bcdab; (ii) bacb (C) (i) bcdab; (ii) bcab (D) (i) badcb; (ii) bacb | 1 |
| 6. | A coil of self-inductance L is connected in series with a bulb B and an ac source. Brightness of the bulb decreases when (A) frequency of the ac source is decreased. (B) number of turns in the coil is reduced. (C) a capacitance of reactance $X_c = X_L$ is included. (D) an iron rod is inserted in the coil. | 1 |
| 7. | What is the value of inductance L for which the current is maximum in a series LCR circuit with $C = 10 \mu\text{F}$ and $\omega = 1000 \text{ rad/s}$? (A) 100 mH (B) 1 mH (C) 10 mH (D) cannot be calculated unless R is known | 1 |
| 8. | According to Maxwell 's equation the velocity of light in any medium is expressed as (A) $\frac{1}{\sqrt{\mu_0 \epsilon_0}}$ (B) $\frac{1}{\sqrt{\mu \epsilon}}$ (C) $\sqrt{\frac{\mu}{\epsilon}}$ (D) $\sqrt{\frac{\mu_0}{\epsilon}}$ | 1 |

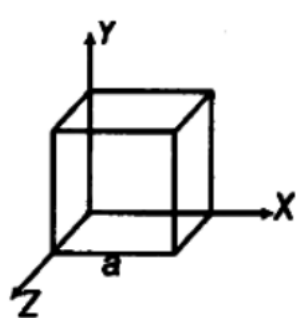
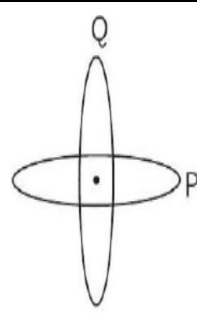

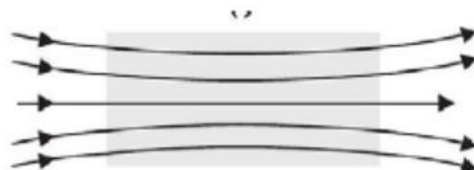
| | | |
|------------------|---|---|
| 15. | <p>Assertion (A): A convex lens of glass ($\mu = 1.5$) behaves as diverging lens when immersed in carbon di sulphide of higher refractive index ($\mu = 1.65$)</p> <p>Reason (R): A divergent lens is thinner in the middle and thicker at the edges</p> | 1 |
| 16. | <p>Assertion (A): Emission line spectra of a material can serve as a type of “fingerprint” for identification of the gas.</p> <p>Reason(R): An excited atomic gas emitted only certain specific wavelengths.</p> | 1 |
| SECTION B | | |
| 17. | <p>Given the electric field in the region $\vec{E} = 2x \hat{i}$, find the net electric flux through the cube and the charge enclosed by it.</p>  | 2 |
| 18. | <p>The resistance of a thin wire of silver is 1.0Ω at 20°C. The wire is placed in a liquid bath and its resistance rises to 1.2Ω. Calculate the temperature of the bath in $^\circ\text{C}$.</p> <p>[Given: $\alpha_{\text{silver}} = 3.8 \times 10^{-3}/^\circ\text{C}$]</p> | 2 |
| 19. | <p>(I) Two identical loops P and Q of radius 5 cm each are lying perpendicular to each other with a common center. Find the magnitude and direction of the net magnetic field if they are carrying 3 A and 4 A each.</p>  <p style="text-align: center;">OR</p> <p>(II) A uniform magnetic field gets modified as shown in figure when two specimens (i) and (ii) are placed in it.</p> <p>(A) Identify the specimen (i) and (ii).</p> <p>(B) How is the magnetic susceptibility of specimen (i) different from that of specimen (ii)?</p> <div style="display: flex; justify-content: space-around; align-items: flex-start;"> <div style="text-align: center;"> <p>(i)</p>  </div> <div style="text-align: center;"> <p>(ii)</p>  </div> </div> | 2 |

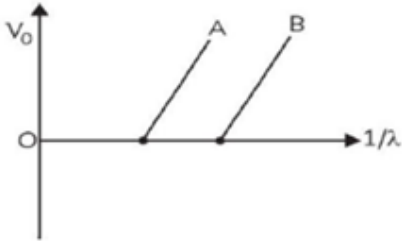
| | | |
|------------------|--|---|
| 20. | In a plane EM wave, the electric field oscillates sinusoidally at a frequency of 2×10^{10} Hz and amplitude 48 Vm^{-1} . (I) What is the wavelength of wave? (II) What is the amplitude the oscillating magnetic field? | 2 |
| 21. | <p>(I) Figure shows the stopping potential (V_0) for the photoelectron versus $\frac{1}{\lambda}$ graph, for two metals A and B, λ being the wavelength of incident light. How is the value of Planck's constant determined from the graph?</p> <div style="text-align: center;">  </div> <p style="text-align: center;">OR</p> <p>(II) The ground state energy of hydrogen atom is -13.6 eV. If an electron makes a transition from an energy level -1.51 eV to -3.4 eV, calculate the wavelength of the spectral line emitted and name the series of hydrogen spectrum to which it belongs.</p> | 2 |
| SECTION C | | |
| 22. | <p>(I) A proton, a deuteron and an alpha particle are accelerated through the same potential difference and then subjected to a uniform magnetic field \vec{B}, perpendicular to the direction of their motions. Compare</p> <p>(A) their kinetic energies, and</p> <p>(B) if the radius of the circular path described by proton is 5 cm, determine the radii of the path described by deuteron and alpha particle.</p> <p style="text-align: center;">OR</p> <p>(II) A short bar magnet of magnetic moment $M = 0.3 \text{ J T}^{-1}$ is placed in a uniform external magnetic field of 0.50 T. If the bar is free to rotate in the plane of the field,</p> <p>(A) Which orientations would correspond to its (i) stable and (ii) unstable equilibrium?</p> <p>(B) What is the potential energy of the magnet in each case?</p> <p>(C) What is the torque on magnet in each case?</p> | 3 |
| 23. | <p>A storage battery is of emf 8 V and internal resistance 0.5 ohm is being charged by d.c supply of 120 V using a resistor of 15.5 ohm.</p> <p>(I) Draw the circuit diagram.</p> <p>(II) Calculate the potential difference across the battery.</p> <p>(III) What is the purpose of having series resistance in this circuit?</p> | 3 |
| 24. | <p>(I) Write two necessary conditions for total internal reflection.</p> <p>(II) Two monochromatic rays of light are incident normally on the face AB of an isosceles right-angled prism ABC. The refractive indices of the glass prism for the two rays '1' and '2' are respectively 1.33 and 1.45. Trace the path of these rays after entering the prism.</p> | 3 |

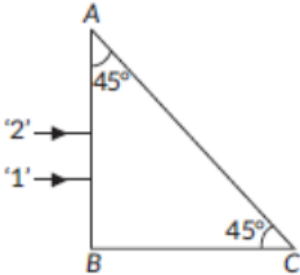
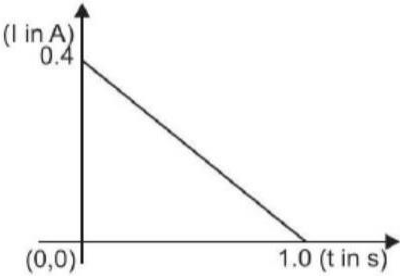
| | | |
|------------------|---|---|
| | <p>[Given: $\sin 43^\circ = 0.69$; $\sin 48^\circ = 0.75$]</p>  | |
| 25. | <p>A plane wave-front propagating in a medium of refractive index 'μ_1' is incident on a plane surface making an angle of incidence (i). It enters into a medium of refractive index μ_2 ($\mu_1 > \mu_2$). Use Huygen's construction of secondary wavelets to trace the refracted wavefront. Hence, verify Snell's law of refraction.</p> | 3 |
| 26. | <p>(I) Differentiate between nuclear fission and nuclear fusion. (Any 2) (II) Deuterium undergoes fusion as per the reaction. Find the duration for which an electric bulb of 500 W can be kept glowing by the fusion of 100 g of deuterium.</p> ${}^2_1\text{H} + {}^2_1\text{H} \rightarrow {}^3_2\text{He} + {}^1_0\text{n} + 3.27\text{MeV}$ | 3 |
| 27. | <p>(I) Draw the energy band diagram of (i) n-type, and (ii) p-type semiconductors at temperature $T > 0$ K. (II) In the case of n-type semiconductor, the donor energy level is slightly below the bottom of conduction band whereas in p-type semiconductor, the acceptor energy level is slightly above the top of valence band. Explain, giving examples, what role do this energy levels play in conduction and valence bands.</p> | 3 |
| 28. | <p>When a conducting loop of resistance 10Ω and area 10 cm^2 is removed from an external magnetic field acting normally, the variation of induced current-I in the loop with time tt is as shown in the figure. Find the</p> <p>(I) Total charge passed through the loop. (II) Change in magnetic flux through the loop. (III) Magnitude of the field applied.</p> |  |
| SECTION D | | |
| 29. | <p>When an external voltage is applied across a semiconductor diode such that p-side is connected to the positive terminal of the battery and n-side to the negative terminal it is said to be forward biased. The applied voltage mostly drops across the depletion region and the voltage drop across the p-side and n-side of the junction is negligible. When an external</p> | 1 Mark each |

voltage is applied across the diode such that n-side is positive and p-side is negative, it is said to be reverse biased. The applied voltage mostly drops across the depletion region.

(I) In the given figure, a diode D is connected to an external resistance $R = 100 \Omega$ and an emf of 3.5 V . If the barrier potential developed across the diode is 0.5 V , the current in the circuit will be:

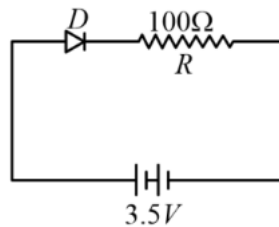

- (A) 40 mA (B) 20 mA (C) 30 mA (D) 36 mA

(II) The V-I characteristic of a diode is shown in the figure. The ratio of the resistance of the diode at $I = 15 \text{ mA}$ to the resistance at $V = -10 \text{ V}$ is

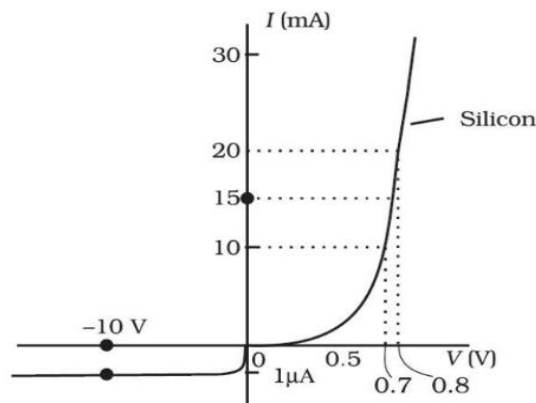

- (A) 100 (B) 10^6 (C) 10 (D) 10^{-6}

(III) In the circuit shown in figure, if the diode forward voltage is 0.3 V , what is the voltage difference between A and B ?

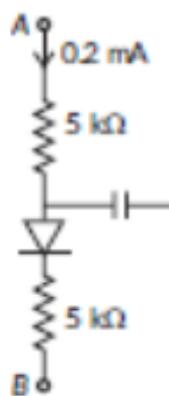

- (A) 0.23 V (B) 2.3 V (C) 1 kV (D) 4 V

(IV) In the following diagrams, indicate which of the diodes are forward biased ?

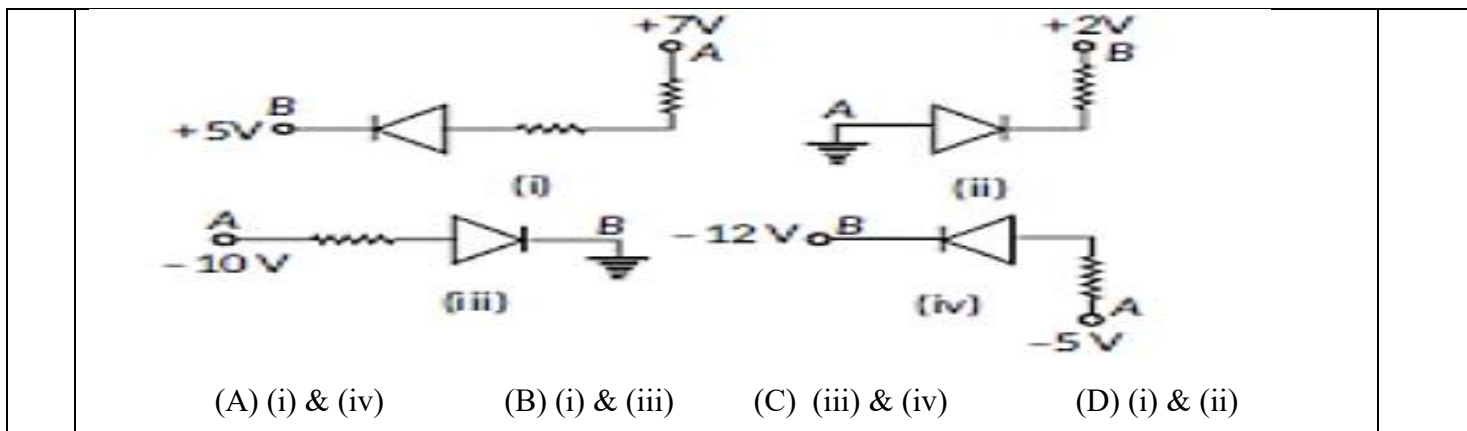

30. **ELECTRON EMISSION** - Minimum energy required to emit the electron from the surface of conductor is called work function (W or Φ_0). It is measured in eV (electron volt). 1 e V- the energy gained by an electron when it is accelerated by a potential difference of 1 volt. Methods of electron emission- (i) Thermionic emission (ii) Field emission (iii) Secondary emission (iv) Photoelectric emission.

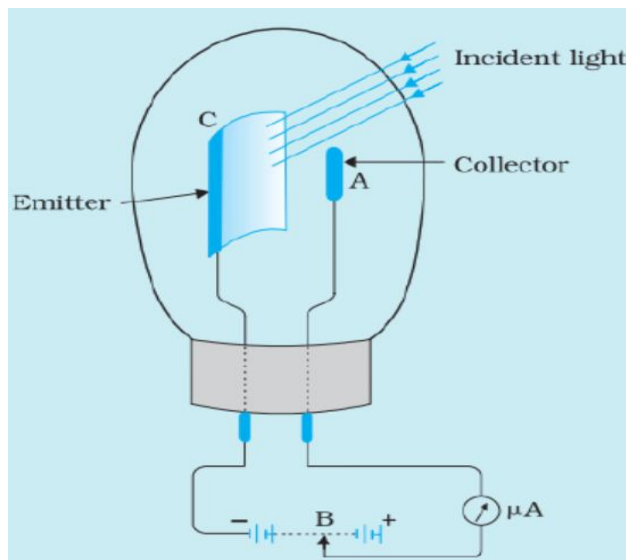

Work function (Φ_0)- the minimum energy

that must be supplied to liberate the weakest bound surface electrons from a metal without giving them any velocity is called the work function of the metal. Work function is a measure in electron volt (eV). Work function depends on the properties of metal and the nature of its surface.

(I) Calculate the maximum frequency and minimum wavelength of X-rays produced by 30 kV electrons respectively. 2

(II) A radio transmitter operates at a frequency 880 kHz and a power of 10 kW. Calculate the number of photons emitted per second. 1

(III) If photoelectrons are ejected from a surface when light of wavelength $\lambda_1 = 550$ nm is incident on it. The stopping potential for such electrons is $V_s = 0.19$ V. Suppose the radiation of wavelength $\lambda_2 = 190$ nm is incident on the surface, Find the stopping potential V_{s2} of surface. 1

SECTION E

31. (I) (A) A parallel plate capacitor of capacitance ' C ' is charged to ' V ' volt by a battery. After some time the battery is disconnected and the distance between the plates is doubled. Now a slab of dielectric constant $1 < K < 2$ is introduced to fill the space between the plates. How will the following be affected? 5

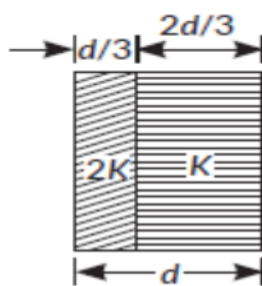
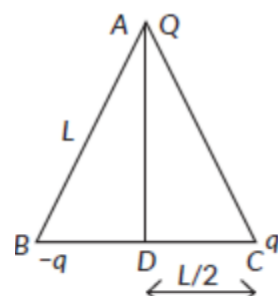
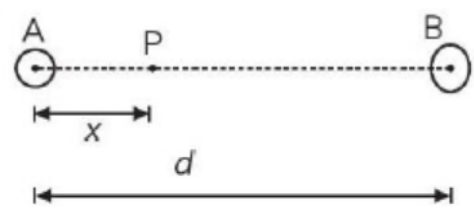
| | | |
|-----|--|---|
| | <p>(i) The electric field between the plates of the capacitor?</p> <p>(ii) The energy stored in the capacitor. Justify your answer in each case.</p> <p>(B) Two slabs of dielectric constants $2K$ and K fill the space between the plates of a parallel plate capacitor of plate area A and plate separation d as shown in figure. Find an expression for capacitance of the system.</p> <p style="text-align: center;">OR</p> <p>(II) (A) Two-point charges q_1 and q_2 are kept r distance apart in a uniform external electric field \vec{E}. Find the amount of work done in assembling this system of charges.</p> <p>(B) Three-point charges Q, q and $-q$ are kept at the vertices of an equilateral triangle of side L as shown in figure. What is</p> <p>(i) the electrostatic potential energy of the arrangement? and</p> <p>(ii) the potential at point D</p> | |
| 32. | <div style="text-align: right;">  </div> <div style="text-align: center;">  </div> <p>(I) (A) Derive lens maker's formula.</p> <p>(B) A point object is placed at a distance of 12 cm on the principal axis of a convex lens of focal length 10 cm. A convex mirror is placed coaxially on the other side of the lens at a distance of 10 cm. If the final image coincides with the object, sketch the ray diagram and find the focal length of the convex mirror.</p> <p style="text-align: center;">OR</p> <p>(II) (A) Draw a ray diagram to show the working of a compound microscope.</p> <p>(B) Obtain the expression for the expression for the total magnification for the final image to be formed at the near point.</p> <p>(C) In a compound microscope an object is placed at a distance of 1.5 cm from the objective of focal length 1.25 cm. If the eye-piece has a focal length of 5 cm and the final image is formed at the near point. Find the magnifying power of the microscope.</p> | 5 |
| 33. | <p>(I) Two long straight parallel wires A and B separated by a distance, d carry equal current I flowing in same direction as shown in the figure:</p> <div style="text-align: center;">  </div> <p>(A) Find the magnetic field at a point P situated between them at a distance 'x' from one wire.</p> <p>(B) Show graphically the variation of the magnetic field with distance x For $0 < x < d$.</p> <p>(C) Define one ampere based on the above concept.</p> <p style="text-align: center;">OR</p> | 5 |

II (A) Draw a labelled diagram of a step-up transformer. Obtain the ratio of secondary to primary voltage in terms of number of turns and currents in the two coils. And also give reasons to explain the following:

(i) The core of the transformer is laminated.

(ii) Thick copper wire is used in windings.

(B) A power transmission line feeds input power at 2200 V to a step-down transformer with its primary windings having 3000 turns. Find the number of turns in the secondary to get the power output at 220 V.