



COMMON PRE-BOARD EXAMINATION
BIOLOGY-Code No. 044
Class-XII-(2025-26)



Time allowed: 3 Hrs.



SET: 2

Maximum Marks: 70

General Instructions:

- (i) All questions are compulsory.
- (ii) The question paper has five sections and 33 questions.
- (iii) Section–A has 16 questions of 1 mark each; Section–B has 5 questions of 2 marks each; Section– C has 7 questions of 3 marks each; Section– D has 2 case-based questions of 4 marks each; and Section–E has 3 questions of 5 marks each.
- (iv) There is no overall choice. Answer all 33 questions. However, internal choices have been provided in some questions. A student has to attempt only one of the alternatives in such questions.
- (v) Wherever necessary, neat and properly labelled diagrams should be drawn.

Section – A		
Q. No.1 to 12 are multiple-choice questions. Only one of the choices is correct. Select and write the correct choice as well as the answer to these questions.		
Q. No	Question	Marks
1.	Which of the following conclusions was drawn from Frederick Griffith’s experiment on <i>Streptococcus pneumoniae</i> ? A. DNA is the genetic material. B. Heat-killed virulent bacteria can become alive. C. A transforming principle can transfer genetic traits. D. Protein is responsible for transformation.	1
2	Given below is a figure of an angiosperm plant, <i>Commelina</i> sp., showing two different types of bisexual flowers, F ₁ and F ₂ . Select the correct option regarding the types of flowers F ₁ and F ₂ and the possible modes of pollination from the table given below. 	1

	Flower F ₁	Flower F ₂	
A	Chasmogamous, self-pollination only	Cleistogamous, cross-pollination only	
B	Chasmogamous, self/cross-pollination	Cleistogamous, cross-pollination only	
C	Cleistogamous, self/cross-pollination	Chasmogamous, self-pollination only	
D	Chasmogamous, self/cross-pollination	Cleistogamous, self-pollination only	
3	<p>The seeds shown below belong to two different plants: Fig. 1, Moringa, and Fig. 2, Litchi. Based on their structures, which of the following statements is most accurate?</p> <div style="display: flex; justify-content: space-around;"> <div style="text-align: center;"> <p>Fig 1</p>  </div> <div style="text-align: center;"> <p>Fig 2</p>  </div> </div> <p>A. Both seeds are adapted for dispersal by water. B. The winged seed is adapted for wind dispersal, while the aril-covered seed attracts animals for dispersal. C. Both seeds are examples of monocot seeds. D. The aril-covered seed is adapted for wind dispersal, while the winged seed is dispersed by animals.</p>		1
4.	<p>The cell which undergoes meiosis-I during spermatogenesis is the</p> <p>A. Spermatogonium B. Spermatid C. Primary spermatocyte D. Secondary spermatocyte</p>		1
5.	<p>Which of the following forms the basis of the DNA fingerprinting technique?</p> <p>A. The presence of identical DNA sequences in all individuals. B. The presence of repetitive DNA sequences that vary between individuals. C. The presence of unique protein markers in blood. D. The presence of mutations in coding regions of DNA.</p>		1
6.	<p>Which of the following statements about evolution is INCORRECT?</p> <p>A. Darwin proposed natural selection as the mechanism of evolution. B. Lamarck believed in the inheritance of acquired characters. C. Genetic drift is a directional process that always favours beneficial traits. D. Industrial melanism is an example of natural selection in action.</p>		1
7.	<p>In autosomal recessive inheritance, which individual(s) in the second generation are most likely carriers?</p> <p>A. Only the affected individuals B. All individuals in the second generation C. Unaffected siblings of affected individuals D. Only males in the second generation</p>		1

8.	Which mRNA will be translated to a polypeptide chain containing 4 amino acids? A. AUGUAAUAGACGAGUAGCGACGAUGU B. AUGAGACGGACUGCAUUCCCAACCUGA C. AUGCCCAACCGUUAUUCAUGCUAG D. AUGUCGACAGUCUAAAACAGCGGG	1
9.	The principle of vaccination is based on the property of A. Specificity B. Diversity C. Memory D. Cell-Mediated Immunity	1
10.	A DNA molecule is 160 base pairs long. It has 30% Guanine. How many adenine bases are present in this DNA molecule? A. 48 B. 64 C. 96 D. 192	1
11.	A single-base insertion occurs between codons 2 and 3 of a 300-codon bacterial gene. Which outcome best describes the protein product? A. Protein with a single amino acid insertion but otherwise normal. B. A protein that is shorter than its normal version (truncated protein) due to an early stop codon in the new reading frame. C. Full-length protein produced by ribosomal frameshifting back to the original frame. D. No effect, because insertions in coding regions are silent.	1
12.	Which among the following is a correctly matched pair? A. Mycorrhizae-mineral uptake from the soil B. Azospirillum-symbiotic nitrogen fixing bacterium C. Rhizobium-parasitic in the roots of legumes D. Azotobacter-free living nitrogen-fixing cyanobacterium	1
<p>Question No. 13 to 16 consist of two statements – Assertion (A) and Reason (R). Answer these questions selecting the appropriate option given below:</p> <p>A. Both A and R are true, and R is the correct explanation of A. B. Both A and R are true, and R is not the correct explanation of A. C. A is true, but R is false. D. A is False, but R is true</p>		
13.	Assertion (A): If the tapetum is malfunctioning in an anther, the male gametophyte often becomes sterile. Reason (R): Tapetum nourishes the developing pollen grains.	1
14.	Assertion (A): Adaptive radiation results in the formation of multiple species from a common ancestor in a short time. Reason (R): Adaptive radiation occurs when a single population experiences stabilising selection in a uniform environment	1
15.	Assertion (A): Opioid abuse leads to both physical dependence and psychological dependence. Reason (R): Opioids activate the mesolimbic reward pathway by increasing dopamine release in the body.	1

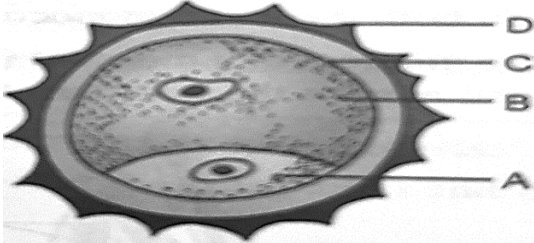
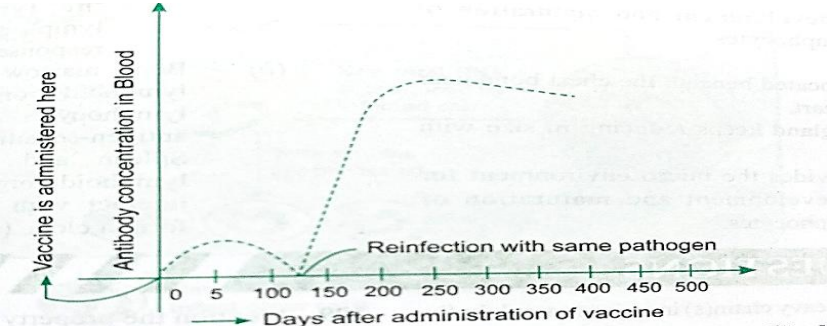
16.	<p>Assertion (A): Golden Rice has been engineered to address vitamin A deficiency. Reason (R): Genes for the β-carotene biosynthesis pathway were transferred into rice endosperm using microinjection of DNA.</p>	1
Section – B		
17	<p>The figure given below represents an important additional step in the transcription of Eukaryotes. Answer the questions below in relation to the figure given below.</p>  <p>a) Identify this additional step in the transcription process of Eukaryotes and state its significance. b) Why do the Eukaryotes carry out this process while the prokaryotes do not?</p>	2
18	<p>Refer to the figure given and match the parts with their names, labelled with their characteristics mentioned.</p>  <p>i) It is made of highly resistant organic material. ii) It is spindle-shaped in outline. iii) It has an irregularly shaped nucleus. iv) It is made of pectin and cellulose.</p> <p style="text-align: center;">OR</p> <p>a) How are Microsporogenesis and Megasporogenesis different from each other in relation to their end product? b) If one can induce parthenocarpy through the application of growth substances, why would watermelon or papaya be a better choice as compared to mangoes?</p>	2
19.	<p>A time-bond vaccination programme is followed for the children in our country from birth up to ten years of age. A graph plotted below shows the effect of the vaccination followed by infection by the same pathogen and the antibody concentration in the blood of the child.</p>  <p>a) Explain why the administration of a vaccine causes an increase in antibody concentration. b) If the child is infected with the same pathogen almost four months later, the antibody concentration in his/her blood increases very fast. Explain why?</p>	2

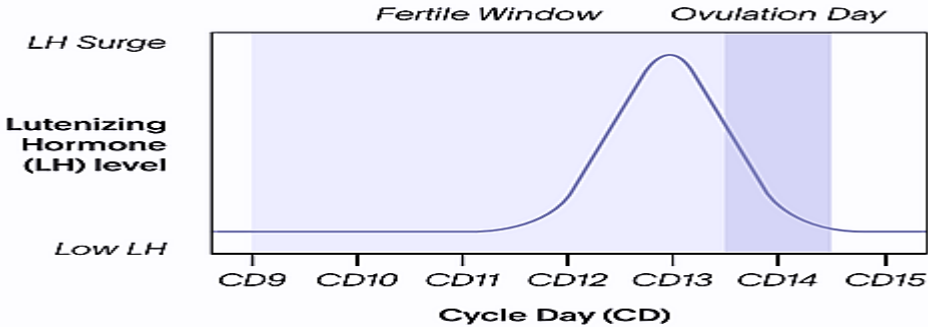
20.	<p>A patient who has been undergoing chemotherapy is suffering from blood coagulation around the central venous catheters that have been used to administer the related drugs.</p> <p>a) Suggest the possible enzyme that could be considered for administration, with the aim of potentially restoring proper blood flow.</p> <p>b) Based on (a), mention the micro-organism from which it is produced?</p> <p>c) Identify the bioactive molecule used as an immunosuppressant in organ transplant patients and also mention its source.</p>	2
21.	<p>a) Predation is generally referred to as a detrimental association. State any two positive roles that a predator plays in an ecosystem.</p> <p>b) State any one chemical defence used by herbivores against their predators.</p>	2
SECTION C		
22.	<p>Sudesh and Mahesh have defective haemoglobin due to genetic disorders. Sudesh has too few globin molecules, while Mahesh has incorrectly functioning globin molecules. Identify the disorder they are suffering from and briefly explain the genetic cause of the disease.</p>	3
23.	<p>Study the graph below showing normal hormonal (LH) changes during a 28-day menstrual cycle. A patient's hormonal profile (LH) shows consistently low levels of LH throughout the cycle.</p> <div style="text-align: center;">  </div> <p>Analyse the impact of this hormonal imbalance on:</p> <p>a) Ovulation timing and Corpus luteum formation.</p> <p>b) Endometrial development and chances of implantation.</p> <p>c) Overall fertility and conception potential.</p>	3
24.	<p>a) A couple is advised in the fertility clinic by the doctor to carry out intracytoplasmic sperm injection (ICSI) as a method of ART. Explain the principle of intracytoplasmic sperm injection (ICSI) and give one advantage of ICSI over conventional IVF.</p> <p>b) What do contraceptive pills contain? Name a non-steroidal oral pill commonly prescribed in India.</p>	3
25.	<p>Assuming that within a population of beetles where Hardy Weinberg conditions are met, the colour black (B) is dominant over the colour red (b), 30% of all beetles are red (bb).</p> <p>Given this information, answer the questions below:</p> <p>a) What is the frequency of homozygous dominant beetles?</p> <p>b) State Hardy Weinberg principle and name any two factors that affect this principle.</p>	3

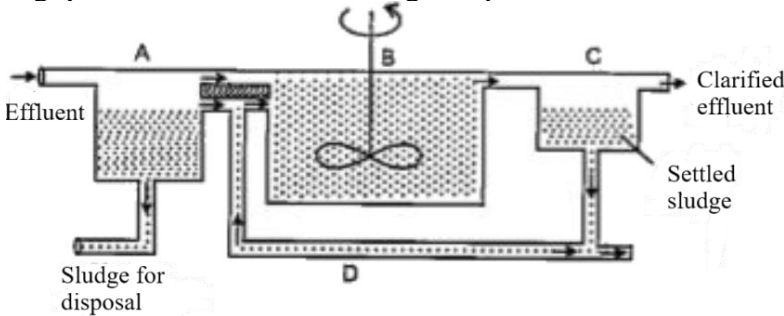
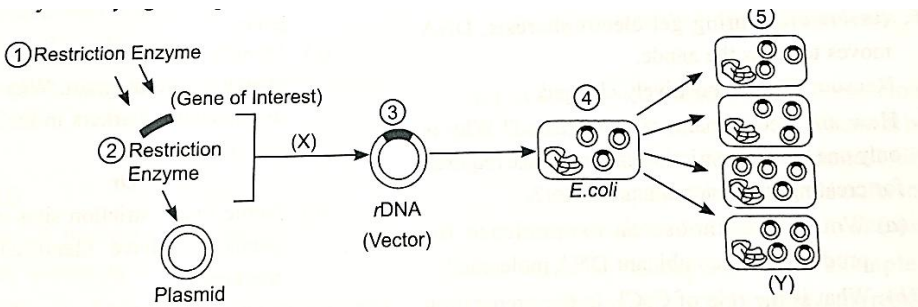
	c) Calculate the percentage of beetles in the population that are heterozygous.	
26	<p>The given diagram shows the steps that take place in the sewage treatment. Answer the following questions in relation to the given process.</p>  <p>a) Explain the steps taking place in the sections marked B & C. b) What would be reduced in the sewage due to this treatment, and how would it benefit the water bodies?</p>	3
27.	<p>Answer either A or B</p> <p>A. Development of rDNA technology has enabled biologists to isolate DNA sequences and manipulate individual genes from diverse cells. Given below is a diagram showing the basic steps involved in GMO. Study the given diagram and answer the questions that follow.</p>  <p>i. Name the enzyme used at step X to integrate the foreign DNA with the vector. ii. Why is the same restriction enzyme used to cut both the foreign DNA and the plasmid? iii. Explain palindrome nucleotide sequence with the help of a suitable example.</p> <p style="text-align: center;">OR</p> <p>B. A gene was introduced into <i>E. coli</i> cloning vector pBR322 at BamH1 site.</p> <p>i. What will be its impact on the recombinant plasmid? ii. Give a possible way by which you could differentiate non-recombinant and recombinant plasmids. iii. pBR322 is a genetically engineered vector. What are the features present in these engineered vectors that help the process of creating rDNA?</p>	3
28.	The graphs (X) and (Y) given below depict the diurnal variations in the solar radiation in June (summer) and in December (winter).	3

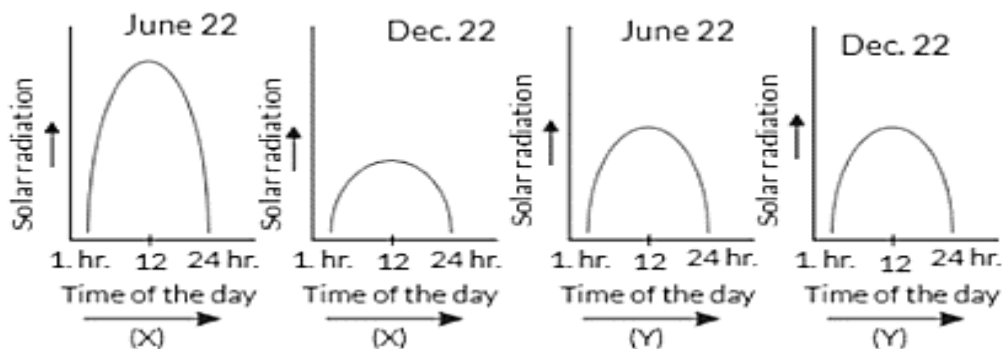

- a) Which of the two graphs (X or Y) depicts a temperate region? Give a reason for your answer.
- b) Which of the two graphs (X or Y) will show high biological diversity, and why?

SECTION D

29. Foetal abnormalities like sickle cell anaemia, cystic fibrosis, etc, are detected by a technique called Amniocentesis. It is performed between 16 to 20 weeks of pregnancy. The foetal cells taken help to detect certain genetic abnormalities in unborn babies.

A. What is the principle behind Amniocentesis?

1

B. How can this technique be misused?

1

Attempt either subpart C or D

C. After the amniocentesis was done, the doctor observed the following Karyotype of the foetus-1, answer in relation to it.

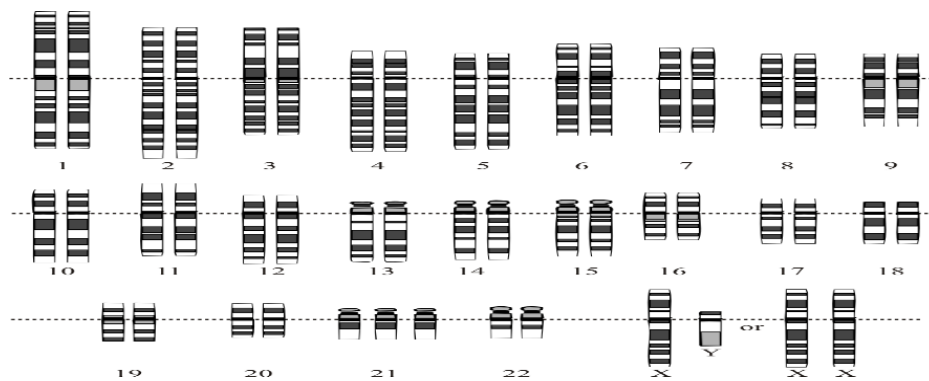

i. Which genetic disorder does the foetus's Karyotype show? Give a reason for your answer.

ii. What is the reason for these kinds of chromosomal disorders?

OR

D. After the amniocentesis was done, the doctor observed the following Karyotype of the foetus-2, answer in relation to it.

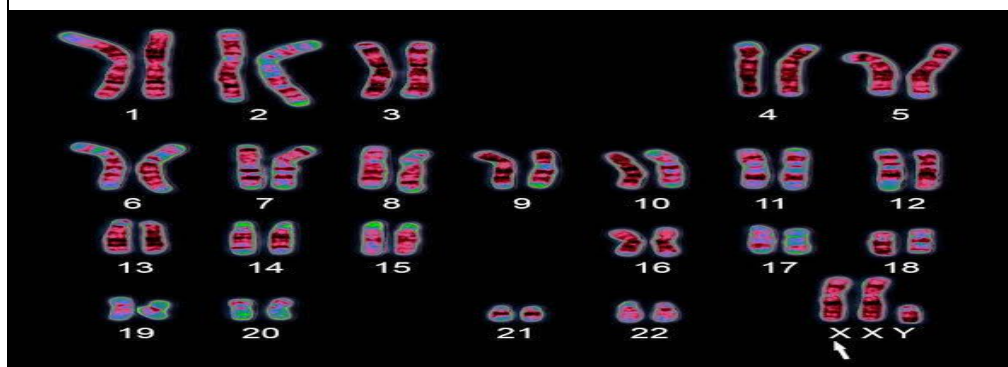

- i. Identify the genetic disorder with a reason
- ii. Give any two abnormalities of this disorder.

30. The Human Immunodeficiency Virus (HIV) is one of the most threatening viral agents. This virus infects approximately 33 million people, many of whom are unaware of their status because, except for flu-like symptoms right at the beginning of the infection during the acute phase, the disease progresses more or less symptom-free for 5 to 10 years. An ideal mathematical model of HIV infection is depicted in the graph given below, which shows the typical course of an HIV infection.

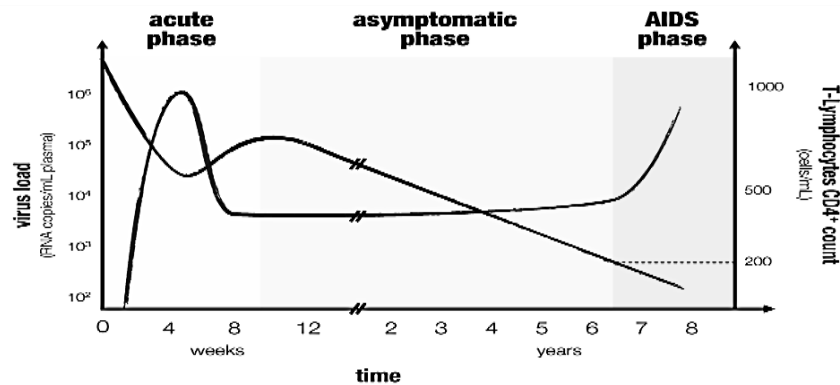

A. Identify the main cause of how the disease spreads and the primary cells it targets.

1

B. Briefly explain the reasons for the three phases depicted in the graph.

1

Attempt either subpart C or D

C. Diagrammatically represent the replication of this virus in the animal cell.

2

OR

D. Name the diagnostic test widely used to detect this disease and the principle behind the test.

SECTION E

31. a) Analyse the pedigree chart given below showing the inheritance of a disease in a family and answer the questions that follow.

5

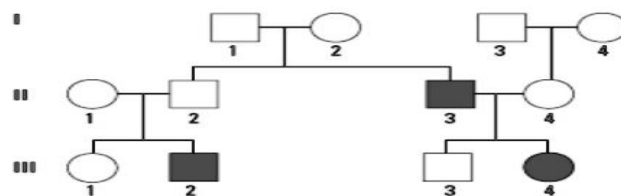

i. Is the disease sex-linked or autosomal? Give a reason for your answer.

ii. Identify the genotype of individual 4 in generation 11 and generation 111

b) Explain the role of histones in DNA packaging.

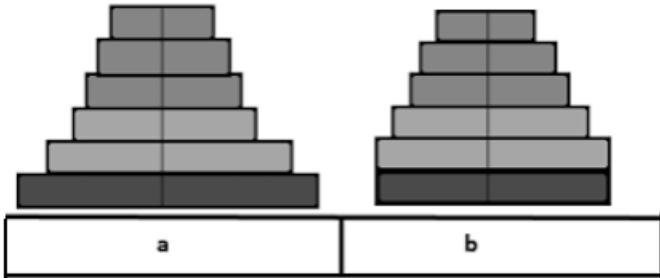
	<p>c) What is a test cross, and why is it carried out?</p> <p style="text-align: center;">OR</p> <p>Given below is one of the strands of a DNA segment:</p> <p>3'TACGTACGTACGTACG 5'</p> <p>a) Write its complementary strand.</p> <p>b) Write the possible strand that can be transcribed by the above DNA molecule.</p> <p>c) Construct a schematic structure of a transcription unit based on the hypothetical template strand given in the question.</p> <p>d) Draw the tRNA for the initiation codon.</p>	
32.	<p>a) State any two approaches used in the treatment of a person suffering from Adenosine Deaminase deficiency. From the different approaches used, which therapy would not require regular revisit by the patient? Explain this method.</p> <p>b) What are the characteristics of 'Stem cells', and from where can one obtain them in humans?</p> <p style="text-align: center;">OR</p> <p>a) Explain how the use of Bt cotton helped in increasing the cotton yield.</p> <p>b) What is tissue culture? Explain how, from a virus-infected banana plant, a virus-free banana plant can be grown using this technique.</p> <p>c) On what principle was a pest resistant tobacco plant genetically engineered?</p>	5
33.	<p>a) What type of population growth is represented by the age pyramids (a and b) given below? Redraw the diagrams and label the tiers. Which pyramid could be a cause of concern for a poor populous country?</p> <div style="text-align: center;">  </div> <p>b) Coevolution is a spectacular example of mutualism between an animal and a plant. Describe this phenomenon with the help of an example.</p> <p style="text-align: center;">OR</p>	5

<p>a) What is Gause's competitive exclusion principle? Who showed that this principle can be avoided? Briefly explain how with an example.</p> <p>b) What is an Ex-situ conservation programme? Explain how, in recent years, this conservation programme has adopted new methods of conservation.</p> <p>c) Give an example to explain how an alien species introduced for aquaculture purposes is threatening our indigenous species of fish in the rivers.</p>	
---	--