



COMMON PRE-BOARD EXAMINATION



SCIENCE Code No. 086 CLASS-X-(2025-26)

SET: 2

Time allowed: 3 Hrs.

Maximum Marks: 80

General Instructions:

Read the following instructions very carefully and follow them:

1. This Question Paper has 3 Sections A - C
2. Section A (Biology) consists of 16 questions and carries a total of 30 marks.
3. Section B (Chemistry) consists of 13 questions and carries a total of 25 marks.
4. Section B (Physics) consists of 10 questions and carries a total of 25 marks.
5. All questions are compulsory. However, an internal choice is provided in some questions. A student is expected to attempt only one of these questions.

Section – A		MARKS																		
1	Which of the following limits the number of trophic levels in a food chain? A. Decrease in energy at higher trophic levels B. Less availability of food C. Polluted air D. Water	1																		
2	Study the graph given below that represents the blood test reports of an athlete just before and after a race. Find the correct statement. <p style="text-align: center;">Blood Lactic Acid Concentration During and After a Race</p> <table border="1"><caption>Data points from the graph</caption><thead><tr><th>Time (in seconds)</th><th>Blood concentration (mmol/L)</th><th>Point</th></tr></thead><tbody><tr><td>0</td><td>1</td><td>A</td></tr><tr><td>10</td><td>4</td><td>B</td></tr><tr><td>30</td><td>4</td><td>C</td></tr><tr><td>45</td><td>11</td><td>D</td></tr><tr><td>55</td><td>5</td><td>E</td></tr></tbody></table> A. Energy is released mainly through aerobic respiration since the oxygen supply to the muscle is adequate. B. Anaerobic respiration increases due to a lack of oxygen, leading to lactic acid accumulation.	Time (in seconds)	Blood concentration (mmol/L)	Point	0	1	A	10	4	B	30	4	C	45	11	D	55	5	E	1
Time (in seconds)	Blood concentration (mmol/L)	Point																		
0	1	A																		
10	4	B																		
30	4	C																		
45	11	D																		
55	5	E																		

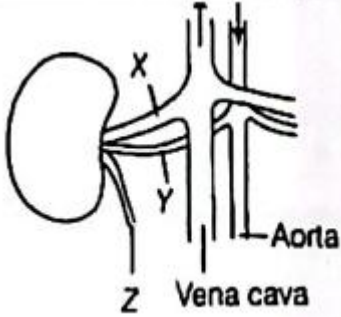
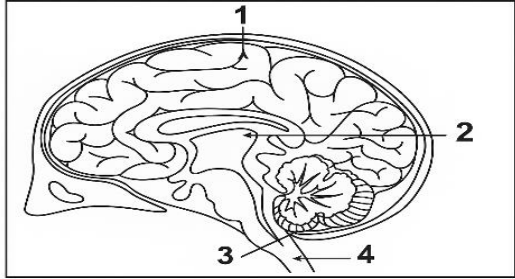
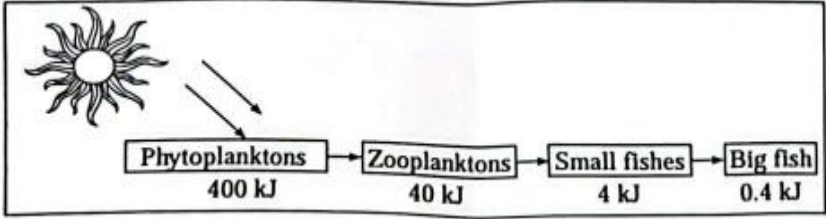
	<p>C. Excess oxygen is used during recovery to oxidise lactic acid into carbon dioxide and water in the liver.</p> <p>D. Muscular respiration has stopped completely, so no energy is produced.</p>	
3	<p>In the given figure, the structures associated with human kidneys are marked (X, Y, Z). The relative concentration of urea in these structures is,</p>  <p>A. X is sometimes higher than Y.</p> <p>B. Y is always higher than Z.</p> <p>C. Y is always lower than Z.</p> <p>D. Z is sometimes lower than X.</p>	1
4	<p>The following diagram represents the external view of the human brain. What happens if part 3 is damaged?</p>  <p>A. Involuntary actions like blood pressure, salivation, etc., are affected.</p> <p>B. Reflex actions are not maintained.</p> <p>C. Posture and balance of the body are not maintained.</p> <p>D. There is no proper intelligence.</p>	1
5	<p>What is depicted in the following schematic representation?</p>  <p>A. 10% Law of energy</p> <p>B. 100% Law of energy</p>	1

	C. 1% Law of energy D. 1000% Law of energy	
6	A homozygous dominant guinea pig with black fur is crossed with a homozygous guinea pig with white fur. The F1 generation is crossed with itself. What percentage of the F2 generation is expected to show a white fur coat? A. 25% B. 50% C. 75% D. 100%	1
7	Person X suffers from a condition that affects the normal functioning of the pituitary gland. Which of the following is most likely a direct effect of person X's condition? A. Insufficiency of iodine B. Irregular heartbeat C. Insufficient growth of the body D. Inability to regulate blood sugar	1
<p>The following two questions consist of two statements – Assertion (A) and Reason (R). Answer these questions by selecting the appropriate option given below: A. Both A and R are true, and R is the correct explanation of A. B. Both A and R are true, and R is not the correct explanation of A. C. A is true, but R is false. D. A is false, but R is true.</p>		
8	Assertion(A): Each human trait is influenced by both paternal and maternal DNA. Reason (R): As compared to the father, the mother contributes more amount of genetic material to the child.	1
9	Assertion(A): Biodegradable substances result in the formation of compost and natural replenishment. Reason(R): It is due to the breakdown of complex inorganic substances into simple organic substances.	1
10	Observe the diagram and answer the following questions.	2

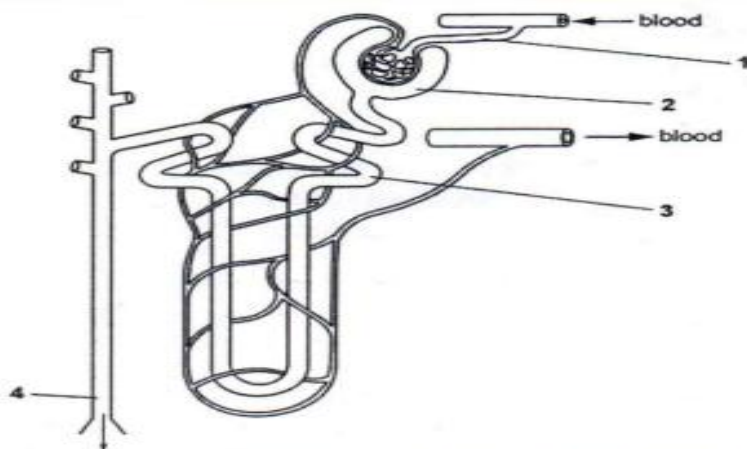

- i) Mention any two substances present in region 2 but not present in region 4. Give a reason.
- ii) What is the capillary cluster in the basic filtration unit called? How does it work in association with region 2 to produce urine?

11	<p>Students to attempt either option A or B.</p> <p>A. Oxygen, mostly, is carried by a pigment in our blood, whereas carbon dioxide is transported in dissolved form in our blood. Give two reasons that make the above statement correct.</p> <p style="text-align: center;">OR</p> <p>B. People often complain about acidity in the stomach.</p> <ol style="list-style-type: none"> i) Which substance is overproduced in the stomach that causes this condition? ii) State why the production of this substance is essential? 	2
12	<p>The water body was affected by runoffs from farms, and DDT infiltrated aquatic plants and animal life there. Herons in that ecosystem fed on these fish. Over time, the chemical disrupted their ability to lay eggs with strong shells, causing their population to deplete.</p> <ol style="list-style-type: none"> i) Identify this phenomenon. ii) How does it affect organisms belonging to different trophic levels, particularly the tertiary consumers? 	2
13	<p>Mendel studied the inheritance pattern of traits in a pea plant. According to this study, he obtained 9: 3: 3:1 ratio for certain traits in the progeny of F₂ generations. Based on it, answer these questions:</p> <ol style="list-style-type: none"> i) Which trait did he study? How do they represent themselves? ii) What was the trait of the progeny of F₁? iii) Which rule does this inheritance pattern suggest? 	3

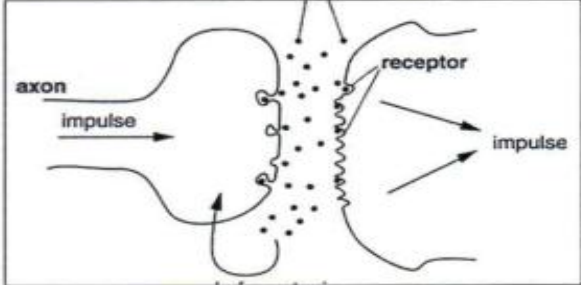
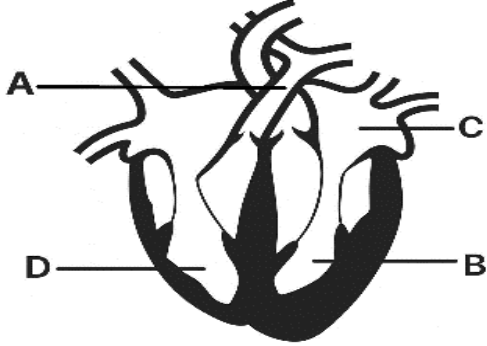
14	<p>i) The leaves of the Chhui-mui plant begin to fold up and droop in response to a stimulus. Name the stimulus and write the cause for such a rapid moment. Is there any growth involved in the movement?</p> <p>ii) The diagram below shows the path by which impulses travel from one neuron to another. What happens when the electrical impulse reaches the axon terminal of the first neuron? How does the impulse continue its journey uninterrupted?</p> 	3
15	<p>A 50-year-old man experiences chest pain and shortness of breath while climbing the staircase. He visits the doctor who performs an ECG and finds a blockage in the blood vessel that is labelled as A in the diagram given below.</p>  <p>Attempt either subpart A or B.</p> <p>A. Name the blood vessel in which the block was detected. State one main function and any two characteristic features of this type of blood vessel.</p> <p style="text-align: center;">OR</p> <p>B. (i) Explain how the structure of the human heart ensures complete separation of oxygenated and deoxygenated blood. (ii) How does this structural adaptation provide an advantage to warm-blooded animals like humans?</p> <p>C. Identify the heart chamber labelled as B. Explain the role of this chamber in circulation.</p> <p>D. Which blood vessel brings blood to the chamber labelled as C? State the type of blood that enters this chamber.</p>	4

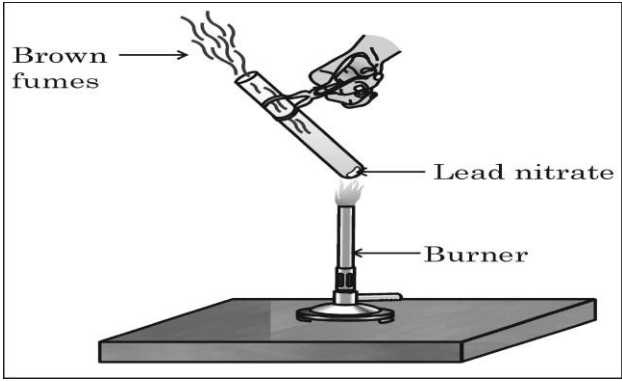
16	<p>A.</p> <p>i) Name the human male reproductive organ that produces sperm and also secretes a hormone. Write the functions of the secreted hormone.</p> <p>ii) Draw a diagram of a human female reproductive system and label the part</p> <p>a) where fusion of egg and sperm takes place.</p> <p>b) where the zygote is implanted.</p> <p>iii) Explain how the embryo gets nourishment inside the mother's body.</p> <p style="text-align: center;">OR</p> <p>B.</p> <p>i) Distinguish between cross-pollination and self-pollination.</p> <p>ii) Mention the site and product of fertilisation in a flower.</p> <p>iii) Draw a labelled diagram of a pistil showing the following parts: Stigma, Style, Ovary, Female germ cell.</p>	5
Section – B		
17	<p>Choose the correct option from the following.</p> $\text{Pb}(\text{NO}_3)_2 + 2\text{KI} \rightarrow \underline{\hspace{2cm}} + 2\text{KNO}_3$ <p>A. PbI_2</p> <p>B. PbI</p> <p>C. $\text{Pb}(\text{NO}_3)_2$</p> <p>D. PbIO_3</p>	1
18	<p>On adding 2 mL of acetic acid to 2 mL of water in a test tube, it was observed that</p> <p>A. A clear and transparent solution is formed.</p> <p>B. A white precipitate is formed almost immediately.</p> <p>C. A colourless and odourless gas is evolved.</p> <p>D. Two separate layers were formed.</p>	1
19	<p>The emission of brown fumes in the given set-up is due to:</p> <div style="text-align: center;">  <p>The diagram shows a test tube held at an angle over a burner. The test tube is labeled 'Lead nitrate'. A burner is labeled 'Burner'. Brown fumes are shown coming out of the test tube, with an arrow pointing to them labeled 'Brown fumes'.</p> </div> <p>A. Thermal decomposition of lead nitrate, which produces brown fumes of nitrogen dioxide.</p> <p>B. Thermal decomposition of lead nitrate, which produces brown fumes of</p>	1

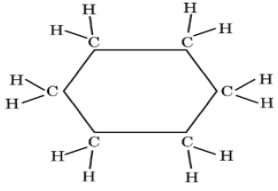
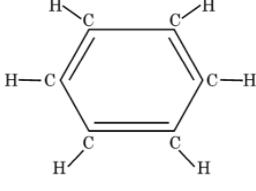
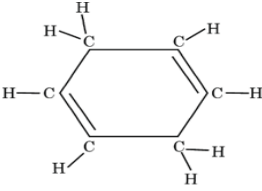
	<p>lead oxide.</p> <p>C. Oxidation of lead nitrate, forming lead oxide and nitrogen dioxide.</p> <p>D. Oxidation of lead nitrate, forming lead oxide and oxygen.</p>	
20	<p>A metal 'X' is used in the thermit process. When X is burnt in air, it gives an amphoteric oxide 'Y'. 'X' and 'Y' are respectively:</p> <p>A. Fe and Fe₂O₃</p> <p>B. Al and Al₂O₃</p> <p>C. Fe and Fe₃O₄</p> <p>D. Al and Al₃O₄</p>	1
21	<p>Consider the structures of the three cyclic carbon compounds A, B and C given below and select the correct option from the following.</p> <div style="display: flex; justify-content: space-around; align-items: center;"> <div style="text-align: center;">  <p>A</p> </div> <div style="text-align: center;">  <p>B</p> </div> </div> <div style="text-align: center; margin-top: 20px;">  <p>C</p> </div> <p>A. A and C are isomers of hexane, and B is benzene.</p> <p>B. A is an isomer of hexene, B is benzene, and C is an isomer of hexene.</p> <p>C. A is a saturated cyclic hydrocarbon, and B and C are unsaturated cyclic hydrocarbons.</p> <p>D. A is cyclohexane, and B and C are isomers of benzene.</p>	1
22	<p>Which of the following statements about the given reaction are correct?</p> $3\text{Fe (s)} + 4\text{H}_2\text{O (g)} \rightarrow \text{Fe}_3\text{O}_4 \text{ (s)} + 4\text{H}_2 \text{ (g)}$ <p>(i) Iron metal is getting oxidised.</p> <p>(ii) Water is getting reduced.</p> <p>(iii) Water is acting as a reducing agent.</p> <p>(iv) Water is acting as an oxidising agent.</p> <p>A. (i), (ii) and (iii)</p> <p>B. (i) and (iv)</p> <p>C. (i), (ii) and (iv)</p> <p>D. (ii) and (iv)</p>	1
23	<p>When you add a few drops of acetic acid to a test tube containing sodium carbonate powder, which one of the following is your observation?</p> <p>A. No reaction takes place.</p> <p>B. A colourless gas with a pungent smell is released with brisk effervescence.</p> <p>C. A brown coloured gas is released with brisk effervescence.</p> <p>D. Formation of bubbles of a colourless and odourless gas.</p>	1

<p>The following question consists of two statements – Assertion (A) and Reason (R). Answer these questions by selecting the appropriate option given below:</p> <p>A. Both A and R are true, and R is the correct explanation of A. B. Both A and R are true, and R is not the correct explanation of A. C. A is true, but R is false. D. A is false, but R is true.</p>		
24	<p>Assertion (A): Sodium oxide is an amphoteric oxide. Reason (R): Metal oxides which react with both acids as well as bases are known as amphoteric oxides.</p>	1
25	<p>A pale green solution of ferrous sulphate was taken in four separate test tubes marked I, II, III and IV. Pieces of Cu, Zn and Al were dropped in test tubes II, III and IV, respectively.</p> <p>(a) In which case will the colour of the ferrous sulphate solution match the colour in test tube I? Give a reason. (b) In which case will the colour of ferrous sulphate solution fade and black mass be deposited on the surface of the metal? Give a reason.</p>	2
26	<p>In the electrolysis of water,</p> <p>A. Name the gases liberated at the anode and cathode. B. Why is the volume of gas collected on one electrode two times that on the other electrode? C. What would happen if dil. H_2SO_4 is not added to water?</p>	3
27	<p><u>Attempt either option A or B.</u></p> <p>A. (i) Write the electronic configuration of magnesium and oxygen. (ii) Give two general properties of the compound formed by the combination of magnesium and oxygen. (iii) Show the formation of this compound by the transfer of electrons.</p> <p style="text-align: center;">OR</p> <p>B. (i) An ore on treatment with dilute hydrochloric acid produces brisk effervescence. Name the type of ore with one example. (ii) Write the balanced chemical equations involved in the extraction of the metal from the given ore. (iii) Calcium starts floating when it is added to water. Give a reason.</p>	3
28	<p>A teacher provided acetic acid, pure water, lemon juice, aqueous solution of sodium hydrogen carbonate and sodium hydroxide to students in the school laboratory to determine the pH values of these substances using pH papers. One of the students reported the pH values of the given substances as 3, 12, 4, 8 and 14, respectively.</p> <p>A. Which one of these values is not correct? Write its correct value, stating the reason. B. 'Sodium hydrogen carbonate is a basic salt.' Justify this statement. How is it converted into washing soda? Write the balanced chemical equation.</p>	4

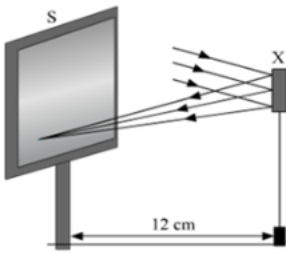
	OR	
	<p>When you add sodium hydrogen carbonate to acetic acid in a test tube, a gas is liberated immediately with a brisk effervescence. Name this gas. Describe the method of testing this gas.</p> <p>C. Select the use of sodium hydroxide from the following.</p> <p>(i) Oxidising agent in chemical industries (ii) Soda-acid fire extinguisher (iii) De-greasing metals (iv) Ingredient in antacids</p>	
29	<p><u>Attempt either option A or B.</u></p> <p>A.</p> <p>A saturated organic compound 'A' belongs to the homologous series of alcohols. On heating 'A' with concentrated sulphuric acid at 443 K, it forms an unsaturated compound 'B' with molecular mass 28 u. The compound 'B', on addition of one mole of hydrogen in the presence of Nickel, changes to a saturated hydrocarbon 'C'.</p> <p>(i) Identify A, B and C. (ii) Write the chemical equation showing the conversion of A into B. (iii) What happens when compound C undergoes combustion? (iv) State one industrial application of hydrogenation reaction. (v) Name the products formed when compound A reacts with sodium.</p> <p style="text-align: center;">OR</p> <p>B.</p> <p>(i) Name the simplest saturated hydrocarbon. Draw its electron dot structure. (ii) Which type of bonds exist in this compound? (iii) Name any two fuel mixtures we use in daily life that contain the above-mentioned carbon compound. (iv) In which homologous series of carbon compounds can this compound be placed? Write the general formula of the series. (v) Which type of flame is produced on burning it?</p>	5
	Section – C	
30	<p>Study the following diagram and select the correct statement about the device 'X':</p> <div style="text-align: center;">  </div> <p>A. Device 'X' is a concave mirror of radius of curvature 12 cm.</p>	1

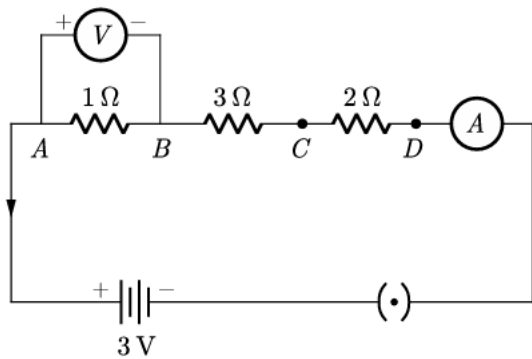
	<p>B. Device 'X' is a concave mirror of focal length 6 cm. C. Device 'X' is a concave mirror of focal length 12 cm. D. Device 'X' is a convex mirror of radius of curvature 12 cm.</p>	
31	<p>During a science exhibition, students pass a beam of white light through a triangular glass prism and notice a spectrum on the wall. If they use a second identical prism inverted with respect to the first, what will they observe?</p> <p>A. Two spectra side by side. B. A bright white light again. C. Only red and blue colours are visible. D. A dark shadow.</p>	1
<p>The following question consists of two statements – Assertion (A) and Reason (R). Answer these questions by selecting the appropriate option given below: A. Both A and R are true, and R is the correct explanation of A. B. Both A and R are true, and R is not the correct explanation of A. C. A is true, but R is false. D. A is false, but R is true.</p>		
32	<p>Assertion (A): When the object is placed at 2F in front of a convex lens, the image is formed at 2F on the other side. Reason (R): The magnification produced in this case is +1.</p>	1
33	<p><u>Attempt either option A or B.</u> A. Study the circuit given below:</p>  <p>(i) What would be the reading of the ammeter? (ii) What would be the reading of the voltmeter?</p> <p style="text-align: center;">OR</p> <p>B.</p> <p>(i) Draw a schematic diagram of a circuit consisting of a 24 V battery, a 10 Ω resistor, a 5 Ω resistor, a 1 Ω resistor, an ammeter and a plug key, all connected in series. (ii) Calculate the ammeter reading in this circuit.</p>	2
34	<p>A real image, $\frac{1}{5}$th size of an object, is formed at a distance of 18 cm from a mirror. What is the nature of the mirror? Calculate its focal length.</p>	2

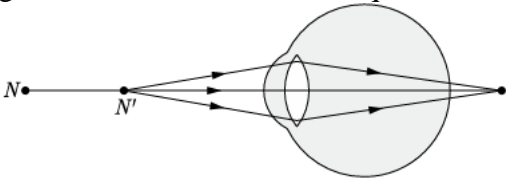
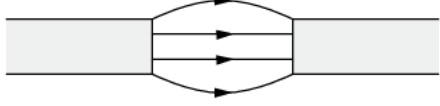
35	<p>Study the diagram given below and answer the questions that follow:</p>  <p>(i) Name the defect of vision represented in the diagram. Give a reason for your answer.</p> <p>(ii) List two causes of this defect.</p> <p>(iii) With the help of a diagram, show how this defect of vision is corrected.</p>	3
36	<p>State Ohm's law. A copper wire has a diameter of 0.5 mm and a resistivity of $1.6 \times 10^{-6} \Omega \text{ cm}$. How much of this wire would be necessary to make a resistance of 10Ω?</p>	3
37	<p>(i) Two magnetic field lines do not intersect each other. Why?</p> <p>(ii) Identify the poles of the magnet in the given figure.</p>  <p>(iii) Draw a figure of current carrying solenoid and show magnetic field lines inside and outside it.</p>	3
38	<p>In a specialised slide projector, slides are small transparencies mounted in sturdy frames, ideally suited to magnification and projection, since they have a very high resolution and a high image quality. There is a tray where the slides are to be put into a particular orientation so that the viewers can see the enlarged, erect images of the transparent slides. This means that the slides will have to be inserted upside down in the projector tray.</p> <p>To show her students the images of insects that she investigated in the lab, Mrs Iyer brought a slide projector. Her slide projector produced a 500 times enlarged and inverted image of a slide on a screen 10 m away.</p> <p>A. Based on the text and data given in the above paragraph, what kind of lens must the slide projector have?</p> <p>B. If 'v' is the symbol used for image distance and 'u' for object distance, then, with one reason, state what will be the sign for $\frac{u}{v}$ in the given case?</p> <p>Attempt either subpart C or D.</p> <p>C. A slide projector has a convex lens with a focal length of 20 cm. The slide is placed upside down 21 cm from the lens. How far away should the screen be placed from the slide projector's lens so that the slide is in focus?</p> <p style="text-align: center;">OR</p> <p>D. When a slide is placed 15 cm behind the lens in the projector, an image is formed 3 m in front of the lens. If the focal length of the lens is 14 cm, draw a ray diagram to show image formation.</p>	4

A.

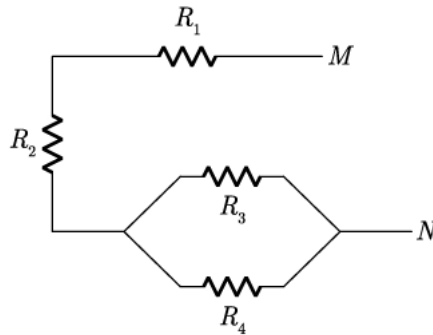

- (i) For the combination of resistors shown in the above figure, find the equivalent resistance between M and N if $R_1 = 10 \Omega$, $R_2 = 20 \Omega$, $R_3 = 30 \Omega$, $R_4 = 60 \Omega$.
- (ii) State Joule's law of heating. Write its expression and explain the terms.
- (iii) Why do we need a 5 A fuse for an electric iron which consumes 1 kW power at 220 V?

OR

B.

- (i) Calculate the equivalent resistance from the following combination of resistors:

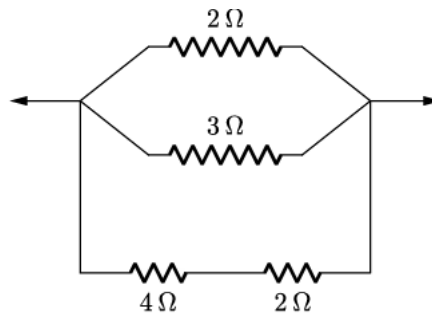

- (ii) Calculate the total cost of running an electric heater of 1000 W for 5 hours daily in September, if the rate of 1 unit of electricity is Rs 6.00.
- (iii) Write any two applications of the heating effect of current.