



# COMMON PRE-BOARD EXAMINATION :2022-23



## Class-X Subject: SCIENCE - 086

Date: 19/01/2023

### General Instructions:

1. This question paper consists of 39 questions in 5 sections.
2. All questions are compulsory. However, an internal choice is provided in some questions. A student is expected to attempt only one of these questions.
3. Section **A** consists of 20 objective type questions carrying 1 mark each.
4. Section **B** consists of 6 Very Short questions carrying 02 marks each. Answers to these questions should be in the range of 30 to 50 words.
5. Section **C** consists of 7 Short Answer type questions carrying 03 marks each. Answers to these questions should be in the range of 50 to 80 words.
6. Section **D** consists of 3 Long Answer type questions carrying 05 marks each. Answer to these questions should be in the range of 80 to 120 words.
7. Section **E** consists of 3 source-based/case-based units of assessment of 04 marks each with sub-parts.

### SECTION – A

Select and write one most appropriate option out of the four options given for each of the questions 1 – 20

1. What happens when calcium is treated with water?  
I. It does not react with water.  
II. It reacts violently with water.  
III. It reacts less violently with water.  
IV. Bubbles of hydrogen gas formed stick to the surface of calcium.  
(a) I and IV (b) II and III  
(c) I and II (d) III and IV 1
2. The solution with the lowest concentration of  $H^+$  ions is -  
(a) pH= 7 (b) pH=8.6 (c) pH=6.8 (d) pH=2.0 1
3. In the reaction between sodium sulphate and barium chloride solution:  
(I) Exchange of atoms takes place.  
(II) Exchange of ions takes place.  
(III) An insoluble precipitate is formed.  
(IV) More reactive metal displaces a less reactive metal.  
(a) I and III (b) II and III  
(c) II and IV (d) I and II 1

4. The figure given below represents the experiment carried out between concentrated sulphuric acid and sodium chloride.

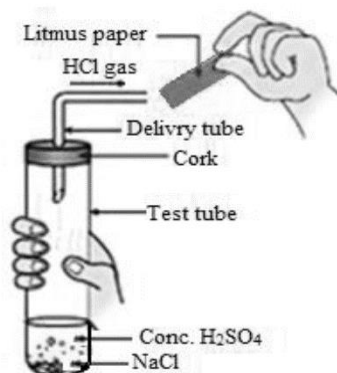

Blue litmus paper is brought near the mouth of the delivery tube to check the presence of acid but no change is observed in the color of litmus paper because:

- (a) The litmus paper used is dry  
 (b) The litmus paper used is moist  
 (c) Blue litmus paper does not change its color with an acid  
 (d) The litmus paper is kept very close to the mouth of the delivery tube 1
5. Solid calcium oxide reacts vigorously with water to form calcium hydroxide accompanied by liberation of heat. This process is called slaking of lime.  
 Which among the following is/are true about slaking of lime and the solution formed?
- (i) It is an endothermic reaction  
 (ii) It is an exothermic reaction  
 (iii) The pH of the resulting solution will be more than seven  
 (iv) The pH of the resulting solution will be less than seven
- (a) (i) and (ii) (b) (ii) and (iii)  
 (c) (i) and (iv) (d) (iii) and (iv) 1
6. Match the chemical substances given in Column (A) with their appropriate application given in Column (B)

Column (A)	Column (B)
(A) Bleaching powder	(i) Removes permanent hardness of water
(B) Milk of Magnesia	(ii) Supports fractured bones
(C) Washing soda	(iii) Oxidising agent
(D) Plaster of Paris	(iv) Antacid

- (a) A—(ii), B—(i), C—(iv), D—(iii)  
 (b) A—(iii), B—(ii), C—(iv), D—(i)  
 (c) A—(iii), B—(iv), C—(i), D—(ii)  
 (d) A—(ii), B—(iv), C—(i), D—(iii)

1

7. Which compound/s will give addition reaction with hydrogen ?

(I)  $C_2H_4$       (II)  $C_2H_6$       (III)  $C_2H_2$       (IV)  $C_3H_8$

(a) I and II                      (b) I and III                      (c) II and IV      (d) III only

1

8.

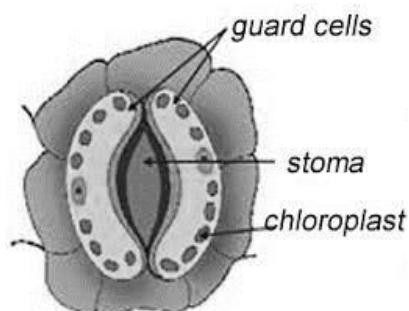

The opening and closing of the stomatal pore depends upon

- (a) oxygen
- (b) temperature
- (c) water in the guard cells
- (d) concentration of  $CO_2$  in stomata

1

9. The reason for diffusion inefficiency in multicellular organisms is

- (a) cell diffusion is a complex process.
- (b) big size and complex body designs.
- (c) cell diffusion requires lot of time.
- (d) cell diffusion is rather a simple process to be carried out in multicellular organisms.

1

10. What is the probability that the progeny will be a boy?

- (a) 50%
- (b) 56%
- (c) 47.43%
- (d) It varies

1

11. Organisms depend on hormones as well as electric impulses for the transmission of signals from the brain to the rest of the body. What can be a likely advantage of hormones over electric impulses?

- (a) It is secreted by all types of cells present in the body.
- (b) It is secreted by stimulated cells and reaches all cells of the body.
- (c) It is relayed to the target organ at a faster rate than electric impulses.
- (d) It does not depend on an external stimulus to be generated in the cells.

1

12. The correct sequence of reproductive stages seen in flowering plants are

- (a) gametes, zygote, embryo, seedling

- (b) zygote, gametes, embryo, seedling
- (c) seedling, embryo, zygote, gametes
- (d) gametes, embryo, zygote, seedling

1

13. A cylindrical conductor of length  $L$  and uniform area of cross section  $A$  has a resistance  $R$ . Another conductor of length  $2L$  and resistance  $R$  of the same material has an area of cross-section

- (a)  $\frac{A}{2}$
- (b)  $\frac{3A}{2}$
- (c)  $2A$
- (d)  $3A$

1

14. A wire is placed between N and S poles of a magnet as shown in figure. If current flows in the wire as shown, in which direction does the wire tend to move?

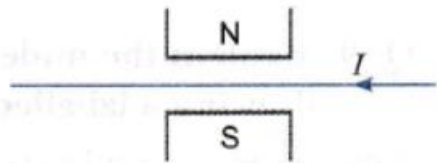

- (a) perpendicular to the plane of paper upward
- (b) perpendicular to the plane of paper downward
- (c) towards east
- (d) towards south

1

15. Bulbs  $B_1$  and  $B_2$  are exactly identical. When the key  $K$  is pressed, the reading of the ammeter will

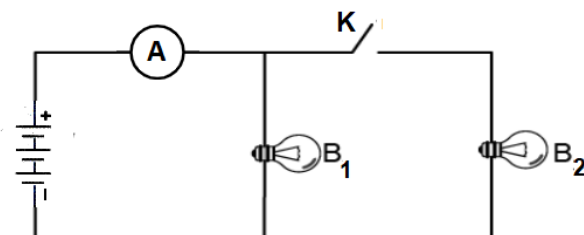

- (a) remain unchanged
- (b) be doubled
- (c) be halved
- (d) become four times

1

16. If the key in the arrangement as shown below is taken out (the circuit is made open) and magnetic field lines are drawn over the horizontal plane ABCD, the lines are

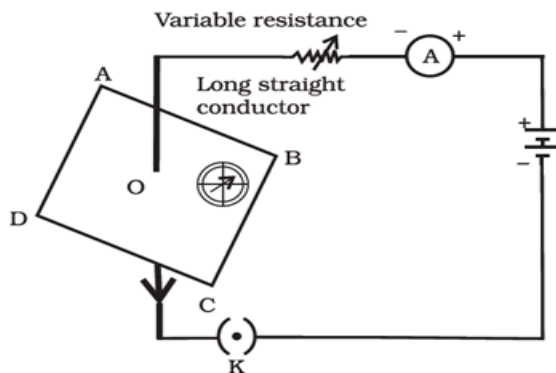

- (a) Concentric circles  
 (b) Elliptical in shape  
 (c) Straight lines parallel to each other  
 (d) Concentric circles near the point O but of elliptical shapes as we go away from it

1

Q. no 17 to 20 are Assertion - Reasoning based questions.

These consist of two statements – Assertion (A) and Reason (R). Answer these questions selecting the appropriate option given below:

- (a) Both A and R are true and R is the correct explanation of A  
 (b) Both A and R are true and R is not the correct explanation of A  
 (c) A is true but R is false  
 (d) A is False but R is true

17. Assertion:  $C_3H_8$  and  $C_4H_{10}$  are the successive members of homologous series of alkanes.

Reason: Any two successive members in a homologous series differ in their molecular formula by a  $-CH_3$  unit.

1

18. Assertion: Dominant allele is an allele, whose phenotype expresses itself even in the presence of another allele of that gene.

Reason: Dominant allele is represented by a capital letter.

1

19. Assertion: In the human heart, there is no mixing of oxygenated and deoxygenated blood.

Reason: Valves are present in the heart which allows the movement of blood in only one direction.

1

20. Assertion : A fuse wire is always connected in parallel with the mainline.

Reason : If too much current flows through the circuit, the fuse wire gets heated too much, melts and breaks the circuit.

1

## SECTION – B

Q. no. 21 to 26 are very short answer questions

21. Give balanced chemical equations for the reactions involved during extraction of zinc from its ore by:
- roasting of zinc ore
  - calcination of zinc ore

OR

- Show the formation of sodium oxide by transfer of electrons.
- Generally, when metals are treated with mineral acids, hydrogen gas is liberated but when metals are treated with  $\text{HNO}_3$ , hydrogen gas is not liberated. Why? 2

22.

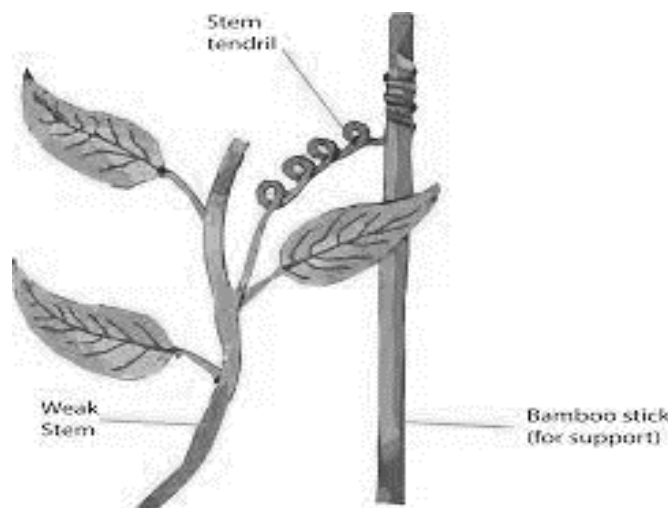

How do auxins promote the growth of a tendril around a support ? 2

23. Why does absorption of digested food occur mainly in the small intestine? 2

24. List out any four different strategies used by plants for excretion. 2

25. What is meant by scattering of light ? State the factor on which the colour of the scattered light perceived by us depends. Why does the sky appear dark instead of blue to an astronaut?

OR

- What do you mean by angle of deviation in a prism ?
- A ray of white light incident along PQ is passing through a glass prism ABC as shown in the diagram.

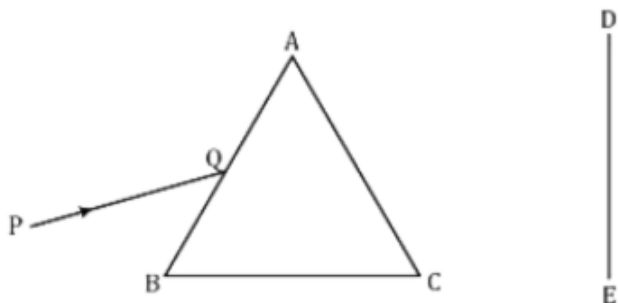

Trace it on your answer sheet and show the path of the emergent beam as observed on the screen DE.

2

26. In the following food chain, plants provide 500J of energy to rats. How much of energy will be available to hawks from snakes ?

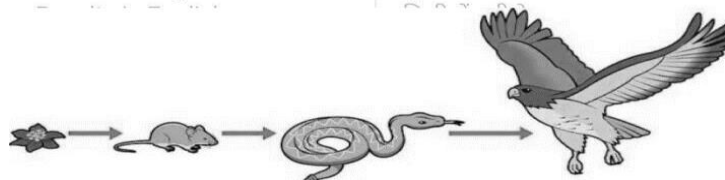

2

### SECTION – C

Q.no. 27 to 33 are short answer questions.

27. On heating blue coloured powder of copper (II) nitrate in a boiling tube, black copper(II) oxide, oxygen gas and a brown gas X is formed.
- Identify the type of reaction and the gas X.
  - Write balanced chemical equation of the reaction.
  - Write the pH range of aqueous solution of the gas X.
28. In the manufacture of sodium hydroxide a gas Y is formed as by-product. This gas reacts with dry slaked lime to give a compound Z, which is used as a bleaching agent in the chemical industry. Identify Y and Z and write balanced chemical equations of the reactions involved.
29. (a) How are lungs designed in human beings to maximize the area for exchange of gases?  
 (b) Why is the rate of breathing in the aquatic organisms much faster than that in terrestrial organisms?

3

3

OR

Explain the process of translocation in plants.

3

30. (a) The radius of curvature of a spherical mirror is 20 cm. What is its focal length?  
 (b) Study the following diagrams :

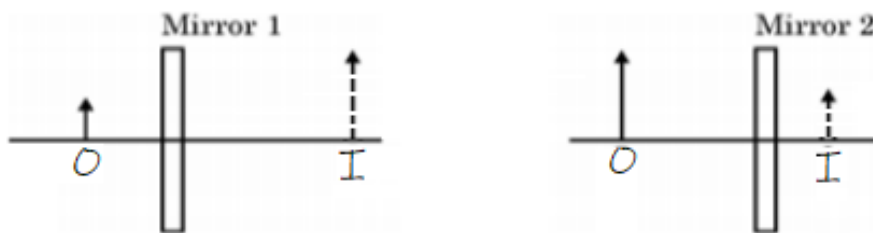

I=Image, O=Object

Identify Mirror 1 and Mirror 2 and state one use of each.

3

31. (a) How is the refractive index of an optical medium related to the speed of light in that medium?  
 (b) A student sitting on the last bench in the class cannot read the writing on the blackboard clearly but he can read the book lying on his desk clearly. List two possible causes for the defect of vision the student is suffering from. What is the focal length of the lens required for correcting his distant vision if he needs a lens of power  $-4$  dioptres for correcting his distant vision?

3

32. Magnetic field lines of two magnets are shown in fig. A and fig. B.



- (a) Select the figure that represents the correct pattern of field lines. Give reasons for your answer. Also name the poles of the magnets facing each other.  
 (b) Why does a compass needle get deflected when brought near a bar magnet?

OR

- (a) Consider a circular loop of wire lying in the plane of the table. Let the current pass through the loop clockwise. Apply the right-hand rule to find out the direction of the magnetic field inside and outside the loop.  
 (b) A circuit contains a battery, a variable resistor and a solenoid. The figure below shows the magnetic field pattern produced by the current in the solenoid.



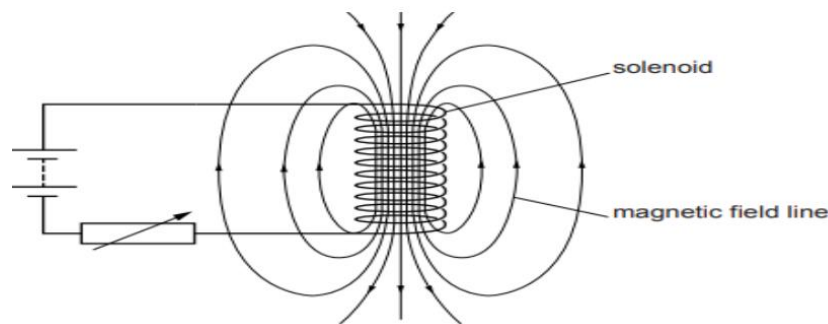

- (i) State how the magnetic field pattern indicates regions where the magnetic field is stronger.  
 (ii) What happens to the direction of magnetic field when the current in the circuit is reversed ?

3

33. Give reasons for the following:

- (a) Flow of energy in an ecosystem is always unidirectional.  
 (b) Ozone is a deadly poison, but is essential at the higher levels of the atmosphere.  
 (c) Decomposers are essential in an ecosystem.

3

### SECTION - D

Q.no. 34 to 36 are Long answer questions.

34. A carboxylic acid (molecular formula  $C_2H_4O_2$ ) reacts with an alcohol in the presence of an acid catalyst to form a compound X. The alcohol on oxidation with alkaline  $KMnO_4$  gives the same carboxylic acid  $C_2H_4O_2$ . Write the name and structure of

- (a) (i) carboxylic acid, (ii) alcohol and (iii) the compound 'X'.  
 (b) Give reasons for the following:  
 (i) Acetylene burns with a sooty flame.  
 (ii) Element carbon forms compound mainly by covalent bonding.

OR

- (a) State the meaning of functional group in an organic compound.  
 Write the formula of the functional group present in  
 (i) aldehydes (ii) ketones  
 (b) How is ethene prepared from ethanol? Give the equation of the reaction involved.  
 (c) Why detergents are better cleansing agents than soaps? Give a demerit of using detergents as cleansing agents.

5

35. (a) Draw a neat diagram of the male reproductive system in humans. Label the following parts- (i) vas deferens (ii) seminal vesicle (iii) prostate gland (iv) testis.  
 (b) Why are the testes located outside the abdominal cavity?  
 (c) Give two examples of bacterial infection, which are sexually transmitted.

OR

- (a) In a bisexual flower if stamens are removed, can it still produce a fruit? Explain.

- (b) List out any two advantages of vegetative propagation.  
 (c) How is binary fission in Leishmania different from that in Amoeba?  
 (d) In an onion plant, the male gamete has 8 chromosomes. How many chromosomes will be found in the zygote?

5

36. (a) In the given circuit, A, B, C and D are four lamps connected with a battery of 60V.

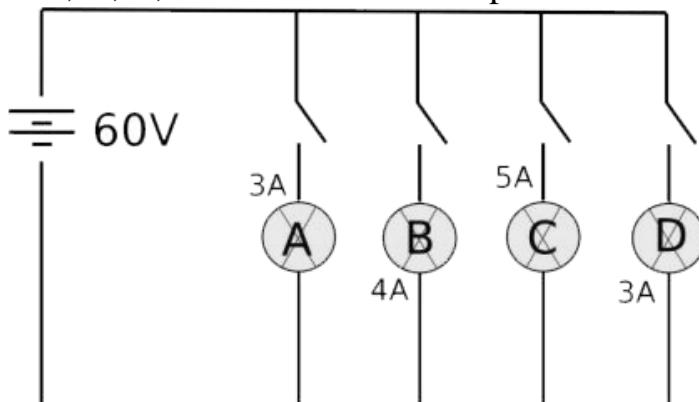

Analyse the circuit to answer the following questions

- (i) What kind of combination are the lamps arranged in (series or parallel)?  
 (ii) Which lamp glows the brightest? Why?  
 (iii) Give two reasons why the combination shown in the above circuit diagram is preferred in domestic electric circuits ?  
 (b) What is the function of an earth wire in a domestic electric circuit?

5

### SECTION - E

Q.no. 37 to 39 are case - based/data -based questions with 3 short sub - parts. Internal choice is provided in one of these sub-parts.

37. Some metals are chemically very reactive whereas others are less reactive or unreactive. Based on vigour of reactions of various metals with oxygen, water, and acids as well as displacement reactions the metals have been arranged in a group or series according to their chemical reactivity. The arrangement of metals in a vertical column in the order of decreasing reactivities is called reactivity series of metals(or activity series of metals). In the reactivity series , the most reactive metal is placed at the top whereas the least reactive metal is placed at the bottom. As we come down in the series the chemical reactivity of metals decreases. Since the metals placed at the bottom of the reactivity series (like silver and gold) are less reactive, so they are usually found in the free state in nature. 4

- (a) Articles made of aluminium do not corrode even though aluminium is an active metal.  
 (b) Of the three metals X, Y and Z. X reacts with cold water, Y with hot water and Z with steam only. Arrange the three metals in the order of increasing reactivity.  
 (c) Which of the metals Al, Cu or Ag can displace hydrogen from hydrochloric acid solution?

Write appropriate chemical equations for any reactions that can occur.

OR

(c) When a piece of copper metal is added to a solution of zinc sulphate, no change takes place, but the blue colour of copper sulphate fades away when a piece of zinc is placed in its solution. Why? Give balanced chemical equation for the reaction that takes place.

38. Mendel crossed a homozygous yellow and round seeded pea plant with another homozygous pea plant bearing green and wrinkled seeds to obtain the  $F_1$  progeny. Then, he selfed the progeny of  $F_1$  generation to obtain the  $F_2$  generation. Mendel observed that there were some characters that were expressed only in the  $F_2$  generation. 4

(a) What will be the genotype of the parent pea plants?

(b) Write down the phenotypic ratio of the plants in the  $F_2$  generation. Mention the type of cross.

(c) List out the phenotypes of the plants obtained in the  $F_2$  generation.

OR

(c) What conclusions can be drawn from the expression of new combination of characters only in the pea plants of the  $F_2$  generation?

39. A transparent material bound by two surfaces, of which one or both surfaces are spherical, forms a lens. A lens may have two spherical surfaces, bulging outwards. Such a lens is called a double convex lens or simply called a convex lens. It is thicker at the middle as compared to the edges. Similarly, a double concave lens is bounded by two spherical surfaces, curved inwards. It is thicker at the edges than at the middle. A double concave lens is simply called a concave lens.

Shown below is the photograph of a convex lens. A small bright spot is seen on the paper when the lens is kept out facing the sun.



When we keep the paper and the lens in the same position for some time, the paper starts burning due to heat generated by the rays concentrated on the spot. 4

(a) Draw a ray diagram to show the image formation in convex lens for the case mentioned in the paragraph.

(b) Name the part of a lens through which a ray of light passes without suffering any deviation?

(c) Rakhi conducts an experiment to produce an image of an object on a screen which is placed at 20 cm from the lens. She uses a convex lens of focal length 15 cm for the experiment. Find the position where she should place the object in order to produce the sharpest image?

OR

(c) The image of an object formed by a lens is of magnification  $-1$ . If the distance between the object and its image is 60 m, what is the nature and focal length of the lens ?